

PV Master 10



USER MANUAL

V2.10



www.neo-messtechnik.com

NEO Messtechnik GmbH
Sonnweg 4, A-2871 Zöbern
Austria
+43 2642 20 301

@ NEO Messtechnik GmbH. All rights reserved.

Page 1 of 113



Thank you!

Thank you very much for your investment in our unique instrument. These are top-quality instruments which are designed to provide you years of reliable service. This guide has been prepared to help you get the most from your investment, starting from the day you take it out of the box, and extending for years into the future.

Support

When you are working with our products we want to provide you with the greatest possible benefits. If you need any support, we are here to assist you.



support@neo-messtechnik.com

www.neo-messtechnik.com

Austria: +43 2642 20301

Switzerland: +41 44 727 75 50

@ NEO Messtechnik GmbH. All rights reserved.

This manual is a publication of NEO Messtechnik GmbH. All rights including translation reserved. This document contains information which is protected by copyright. Reproduction, adaptation, or translation without prior written permission is prohibited, except as allowed under the copyright laws. All trademarks and registered trademarks are acknowledged to be the property of their owners. The product information, technical data and specifications embodied in this manual represent the technical status at the time of writing. Subject to change without notice.

NOTE:

NEO Messtechnik GmbH. shall not be liable for any errors contained in this document. NEO Messtechnik MAKES NO WARRANTIES OF ANY KIND WITH REGARD TO THIS DOCUMENT, WHETHER EXPRESS OR IMPLIED. NEO MESSTECHNIK SPECIFICALLY DISCLAIMS THE IMPLIED WARRANTIES OF MERCHANTABILITY AND FITNESS FOR A PARTICULAR PURPOSE. NEO Messtechnik shall not be liable for any direct, indirect, special, incidental, or consequential damages, whether based on contract, tort, or any other legal theory, in connection with the furnishing of this document or the use of the information in this document.



Table of Contents

1	Introduction	7
2	Safety Information	10
2.1	General Safety	11
2.2	Residual risks	13
2.3	Personal protective equipment	13
2.4	Why use fused test leads?	13
2.5	Cyber Security	14
2.6	Measurement Categories	14
2.7	Battery Handling	16
2.8	Cleaning of the device	18
2.9	Warranty	18
2.10	Recycling	19
2.11	CE Conformity	19
2.12	RoHS	20
2.13	Electrical Units	20
2.14	Environmental and Others	20
3	Hardware	22
3.1	Instrument	22
3.2	Power ON/OFF Switch	23
3.3	Connector Pins	23
3.3.1	Voltage and IV-curve measurement inputs	24
3.3.2	Sensorbox Input	24
3.3.3	Ground connector	24
3.3.4	Current Input	25
3.3.5	WIFI Antenna	25
3.4	Sensor box	26
3.4.1	Sensorbox Basic	26
3.4.2	Sensorbox Expert	28



3.4.3	Install Environmental sensors	30
3.5	Extension box PM10-EXT-20CH	32
3.6	Connection cable for PV+	33
3.6.1	Computer Interface.....	34
3.6.2	Battery indicator LED	35
3.6.3	Fan.....	35
3.6.4	Terms and definitions	35
4	Connection instructions.....	36
4.1	Single channel leakage measurement.....	37
4.2	Single channel IV-curve measurement.....	38
4.2.1	Additional safety / protection check	39
4.3	Multichannel leakage measurement	40
4.4	Multichannel IV-curve measurement	41
4.5	Multichannel IV-curve measurement using common minus.....	42
4.6	Connecting the PM-10	43
5	Software	44
5.1	Start Measurement Software	44
5.2	Sequencing diagram	47
5.3	Main.....	49
5.4	Setup	50
5.4.1	Project.....	50
5.4.2	Module	51
5.4.3	Strings.....	52
5.4.4	Sensor	54
5.4.5	Storing	61
5.4.6	System.....	62
5.5	Leakage measurement	63
5.5.1	String/Array.....	64
5.6	IV Curve.....	65



5.6.1	String/Array.....	66
5.6.2	Data display.....	67
5.6.3	IV Curve/Array Data	67
5.6.4	Array data – Detail/Summary	68
5.6.5	Array Data – Detail	68
5.6.6	Array Data – Summary.....	69
5.6.7	Graphic Tools	70
5.6.8	Cursor Toggle.....	71
5.6.9	Cursor On	72
5.7	Multimeter functions	72
5.7.1	Input source.....	73
5.7.2	Period	74
5.7.3	Display (number of measurement points).....	74
5.8	Automatic Report.....	76
5.9	Automatic Diagnosis	77
6	Quickstart Guide	78
6.1	Disconnect Inverter and Remove Fuses.....	78
6.2	Connect Strings.....	79
6.3	Safety Check (Leakage Test) via PV Master.....	82
6.4	Install Environmental sensors	84
6.5	Instructions for Sensorbox Basic	86
6.6	Instructions for the Sensorbox Expert.....	87
6.6.1	Preparation	87
6.6.2	Launch PV-Master and Connect the Sensorbox	88
6.6.3	Assign Sensors	88
6.6.4	Verify Scaling Factor	90
6.6.5	Save the Setup!.....	91
6.7	Software Setup.....	92
6.8	Execute Measurement	95



7	Further Manuals and Links	97
8	Technical Data and Specifications.....	98
8.1	Accuracy and Signal Conditioning	98
8.2	IV-Curve Specifications	99
8.3	Environment and Mechanical.....	99
8.4	DC Clamp 2000DC.....	101
8.5	PM10 N-type PV Module Testing.....	103
8.6	Power bank usage.....	103
8.7	SENSOR BOX BASIC Ambient Temperature PT100/PT1000 Sensor	104
8.8	SENSOR BOX BASIC Module Temperature PT100 Sensor	106
8.9	PYRANOMETER CLASS A, B and C	107
8.9.1	CLASS C PYRANOMETER	108
8.10	Scope of Delivery	110
8.11	Accessories	111
9	Maintenance and Care	111

MESSTECHNIK



Warning

Failure to follow the warnings and/or instructions for use may damage the device and/or its components and pose a risk to the user.

Always use the newest version of the user manual for instructions on how to use the measurement device. The latest User Manual is available at:

www.neo-messtechnik.com

1 Introduction

This manual contains important instructions for the use and operation of NEO Messtechnik instruments safely, properly and efficiently. Its purpose to help you to avoid danger, repair costs, and down time as well as to help maintain reliability and life of the instruments. For this reason, it is important to ensure that the manual is always available to authorised and trained personnel. Operating personnel should read the manual thoroughly. The manufacturer will not be held liable for any injury or damage to personnel or property through failure to observe the safety precautions contained in this handbook. The specific standards and regulations in each country must also be observed. It is important to observe the general electrical regulations of the country in which the device will be installed and operated, as well as the current national accident prevention regulations and internal company directives (work, operating and safety regulations). The system may only be installed by an authorised electrician. Use genuine accessories to ensure system safety and reliable operation. The use of other parts is not permitted and invalidates the warranty.

The PV Master is an All-in-one measurement instrument for photovoltaic plants combining with the latest technology. It can be used for leakage checks, performance tests and current measurement with high accuracy. The conformity of the device according to international standards enables the user to generate reliable and accurate reports for various applications.

The LCD touch screen, that is also readable under sunlight, proves to be very comfortable for mobile measurement tasks. In combination with the internal battery pack the PV Master operates up to 4,5 hours without any external power source.



Equipped with USB 3.0, Ethernet (Gbit), telecommunication modem, Wi-Fi and Bluetooth, the PV Master enables remote configuration and multi-device monitoring.



Main Features

- IV-curve tracing for up to 20 strings (with the extension box)
Measurement time <200ms
- For voltages up to 1500V per string
- Currents up to 30A per string
- Leakage measurement and Distance to fault for user safety
- Current measurement
- Remote and mobile functions (LAN, WLAN, UMTS)
- Powerful x64-Intel-CPU, up to 8GB Memory
- High speed, high-capacity SSD (2 x 256GB max.)
- Direct analyzing on the sunlight readable multi-touch screen LCD and HDMI port for external monitor
- Versatile PV Performance software including analyzer, data storing, reporting

The instrument is designed to conform to the IEC61010 Safety Standards and has been thoroughly tested for safety prior to shipment. However, using the instrument in a way not described in this manual and instructions may negate the provided safety features. Before using the instrument be certain to carefully read the following safety notes.

Warning sign	Type of safety instruction
	<p>This symbol indicates cautions and hazards that may/will result in death or serious injury to the operator.</p>
	<p>This symbol indicates that dangerous high voltage. If a particular safety check is not performed, this may give rise to a hazardous situation. The operator may receive an electric shock, may be fatally injured or may be burnt.</p>



Tips and recommendations

	This symbol indicates a double-insulated device.
	This symbol indicates advisory items related to the performance or correct operation of the instrument.

Mishandling during use could result in injury or death, as well as damage to the instrument. Be certain that you understand this instructions and precautions in the manual before use.





2 Safety Information

- In order to ensure safe operations of this instrument, all notes and warnings in these instructions must be observed at all times.
- All test leads must be securely attached to the PV system while measuring. Always use the PV Master connectors supplied or alligator clips to connect the test leads to the PV system for measurement. Test probes must not be used without alligator clips.
- Never disconnect the test leads during an active measurement. This may result in electrical arcing and may damage the PV Master.
- Do not attempt to turn off the PV Master during an active measurement.
- The PV Master is intended for use in a dry environment only.
- The PV test terminals maximum rating: 1500V DC open circuit voltage and 30A short circuit current. Do not exceed this rating. The DC supply must be isolated from earth/ground during testing.



MESSTECHNIK



2.1 General Safety

- Carefully read this manual before using the instrument.
- Use the instrument according to these instructions only.
- Use the instruments only under environmental conditions described in the technical data.
- Personnel assigned to use the instrument must have read this reference manual and fully understood the instructions herein.
- The instruments may only be operated by trained personnel. Any maloperation can result in damage to property or persons.
- The input voltage shall not exceed the values rated in the technical data. With this product, only use the power cable delivered or defined for the host country.
- There is no guarantee if you exceed the values for your safety.
- The power supply must be within the limits given in the technical data.
- Always make a visual inspection of used equipment such as leads and clamps before use.
- Use fuses (500mA) if you connect the instrument directly to voltage where no fuse is available or high short circuit power is given.
- The product heats during operation. Make sure there is adequate ventilation. Ventilation slots must not be covered!
- When connecting to the banana plug sockets, only use cables with 4mm/0.16" safety banana connectors and plastic housing. Always insert plugs completely.
- DO NOT insert objects into sockets or ventilation slots.
- DO NOT open the instrument or remove any of its housing components. Don't carry out any modifications, extensions or adaptations at the instrument. If instrument is opened by the customer, all guarantees are invalidated.
- DO NOT use the system if equipment covers or shields are removed.
- DO NOT use the system in rooms with flammable gases, fumes or dust or in adverse environmental conditions.
- The use of the measuring system in schools and other training facilities must be observed by skilled personnel.
- Please contact a professional if you have doubts about the method of operation, safety or the connection of the system.
- Please be careful with the product. Shocks, hits and dropping it from already lower level may damage your system.
- Do not switch on the system after transporting it from a cold into a warm room and vice versa. The thereby created condensation may damage your system. Acclimatize the system unpowered to room temperature.
- Maintenance must be executed by qualified staff only.
- DO NOT operate damaged equipment: Whenever it is possible that the safety protection features built into this product have been impaired, either through physical damage, excessive moisture, or any other reason, REMOVE POWER and do not use the product until safe operation can be verified by service-trained personnel. If necessary, return the product to NEO Messtechnik sales and service office for service and repair to ensure that safety features are maintained.
- This manual is to be supplemented by existing national safety standards for accident prevention and environmental protection.
- The instructions provided in this manual and the associated software and hardware manuals are considered part of the rules governing proper usage.
- Observe local laws when using the instrument.





- The use of measuring devices under CAT II, III or IV conditions can be dangerous! Under these conditions, only appropriately trained / tested / informed about safety precautions may take measurements (for safety categories see also technical reference manual). If a measuring device, a cable or an accessory of a lower category or voltage is used, this lower category / voltage applies to the entire group (device + cable + accessories)
- During shipment of the device, handle it carefully so that it is not damaged due to vibration or shock.
- To avoid electrical shock don't remove the instrument case. The internal components of the instrument carry high voltages and may become very hot during operation.
- Don't use the instrument in environments containing ignitable gases, explosive powders etc. (Risk of explosion)
- Don't place the instrument on an unstable table or an inclined place. Dropping or knocking down the instrument can cause injury or damage to the instrument.
- Don't use the instrument at circuits exceeding its rating and specifications. Doing so may damage the instrument or cause it to become hot, resulting in electric shock or injury to persons.
- Before using the instrument inform those around you of your intention to use it.
- Before using the instrument, verify that it operates normally to ensure that no damage occurred during storage or shipping. If you find any damage, contact your authorized NEO Messtechnik sales partner or contact NEO Messtechnik directly.
- If a test lead or the instrument is damaged, there is a risk of electrical shock. Perform inspection before using the instrument. Check the coating of the test leads that they are neither ripped nor torn and that no metal parts are exposed. Using the instrument under such conditions could result in electric shock. Replace the test leads with those specified by NEO. Verify that the instrument operates normally to ensure that no damage occurred during storage or shipping. If you find any damage, contact NEO Messtechnik or an authorized sales partner.
- During shipment of the instrument, only use the packaging of the original delivery and handle it carefully so that there is no damage due to vibration or shock.
- If the product is damaged, mark it clearly so that no other person uses it inadvertently.
- Touching any high voltage points inside the equipment is very dangerous. Customers are not allowed to modify, disassemble or repair the instrument. Doing so may cause fire, injury or electrical shock.
- The instrument is not drip-proof. Water droplets may result in malfunctions.
- The instrument is designed for the application in low-voltage grids (100V – 230V line-earth and 400V line-to line). Any use in other than specified voltage levels is strongly forbidden.
- Don't short the measurement test leads with metal portion or tips of the test lead. Doing so may cause fire, injury or electrical shock.
- To avoid electrical shock or short-circuit don't touch the metal parts of the connecting cable clips.
- To prevent electrical shock when measuring the voltage or connecting the GIA to the power line use only the specified test lead.
- To prevent electrical shock don't exceed the the lower of the ratings shown on the instrument and test leads.
- The system may only be installed by an authorised electrician.
- The operating safety is only guaranteed if the delivered system is used as intended. Incorrect use may result in danger to the operator, to the system and the connected equipment.
- The operation of NEO Messtechnik products in direct contact with water, aggressive substances and inflammatory gases and vapours is prohibited.





- The system may only be operated whilst it is in perfect working condition. In the event of damage, irregularities or malfunctions that cannot be resolved with the assistance of the operating instructions, the system must be shut down immediately and labelled accordingly. In such an event, the relevant management must be informed. Please contact NEO Messtechnik Service immediately to eliminate the malfunction. The system may only be started up again once the malfunction has been eliminated.
- The instrument is intended for use in a dry environment only.
- In order to ensure safe operations of this instrument, all notes and warnings in these instructions must be observed at all times.
- Never disconnect the test leads during an active measurement. This may result in electrical arcing or electrical shock.
- Wear protective gear to prevent electrical shock. Use appropriate protective insulation and adhere to applicable laws and regulations.
- With regards to the electrical supply, there are risks of electrical shock, heat generation, electrical arc, fire and short circuits. Individuals using an electrical measuring device the first time must be supervised by a technician with experience in electrical measurements.



2.2 Residual risks

The GIA device is designed in accordance with the state of the art and current safety requirements. Nevertheless, residual risks remain that require prudent action.

2.3 Personal protective equipment

Personal protective equipment is used to protect persons from health and safety hazards.

The specific regulations of the respective area or country as well as company regulations for safety in electrical engineering and the safe handling of electronic devices in accordance with EN50110 must be observed.

2.4 Why use fused test leads?

This tester is protected internally by high-integrity fuses and clearance distances appropriate to the installation category and voltage ratings of the instrument.

A hazard may arise during testing where the electrical supply is short-circuited, possibly resulting in an explosion, burnout of test apparatus, arcing, etc. without rupturing the instrument's internal fuse. Fused test leads will rupture, protecting the operator.

Examples of the ways that the supply might be shorted out are:

- Human error on the part of the electrician or someone else working on the system
- A test lead is trapped and shorts down to earthed metalwork



- The integrity of the test apparatus has been damaged by repair, overload, abuse or fault condition etc.

2.5 Cyber Security

The PQA and PM10 products are electrical measuring devices. If they are used stand-alone - without any connection to a company network, no cybersecurity measures are required. If the measuring devices are integrated into a network via LAN, WLAN or a SIM, measures to protect against cyber attacks are necessary. These can either be ensured within the company by applying various protective measures (VLAN, antivirus, etc.). Alternatively, NEO Messtechnik offers cybersecurity protection via endpoint protection on a monthly billing basis. The costs can be requested from your responsible sales partner.

2.6 Measurement Categories

To ensure safe operation of measuring instruments the IEC 61010 safety standard defines several categories for various electrical environments – called measurement categories.



Using a measurement instrument in an environment designated with a higher-numbered category than that for which the instrument is rated could result in a severe accident, and must be carefully avoided.



Never use a measuring instrument that is not labelled with a measurement category according to IEC61010.

Measurement category CAT II

Measurement category II is for measurements performed on circuits directly connected to the low-voltage installation. Examples are measurements on household appliances, portable tools and similar equipment

Measurement category CAT III

Measurement category III is for measurements performed in the building installation. Examples are measurements on distribution boards, circuit-breakers, wiring, including cables, bus-bars, junction boxes, switches, socket-outlets in the fixed installation, and equipment for industries

Measurement category CAT IV

Measurement category IV is for measurements performed at the source of the low-voltage installation. Examples are electricity meters and measurements on primary overcurrent protection devices and ripple control units



For working on equipment under voltage use the guidelines given in EN50110.

Always follow the 5 golden safety rules:



1. Always switch off.

Meaning that the electrical installation must be disconnected from live parts on all poles. Block all poles of the power source for every part of the operation. Switchgear of home or factory, low voltage switch mode, the power of the machine control switch should be cut off. The power supply circuit to be supplied to the electric appliance such as lamps and motors should be cut off. If you remove the low-voltage rapid fuse, you should wear braces, a helmet, and front shields. If there is a capacitor, the residual charge must be discharged using appropriate tools.

2. Secure against reconnection.

Reliably prevent an accidental re-connection of an installation where work is in progress. This is achieved for example by just replacing the unscrewed fuses in the low-voltage system by lockable lock-out devices. Appropriate warning signs should be posted for viewing on the operating device (switch handle, instrument actuator, control device, circuit breaker, etc.). It should also be posted to closed electrical operating areas or locked switch cabinets. The contents of the warning cover should warn you that you don't manipulate the switch. In addition, provide a name for the workplace location and supervisor. The power-off device should be locked to a mechanical device. All keys must be kept in a safe place. If it is operated with the control voltage of the energy or controller, such as springs, compressed air, it must take measures to prevent the release or operation of energy.

3. Verify that the installation is dead

Use a suitable measuring / test equipment such as a voltage detector to verify on all poles that the installation is dead. Check the correct function of the voltage detector prior to using it.

4. Carry out earthing and short-circuiting.

An important point of the five safety rules is earthing and short-circuiting at the workplace. This measure ensures a voltage-free state for the duration of the work, also with regard to influencing voltages, atmospheric overvoltage or accidental restarting. Earthing and short-circuit areas should be visible at the workplace. Important: The relevant parts must be earthed before they are short-circuited!

5. Provide protection against adjacent live parts

According to the five safety rules, adjacent parts are parts located in the vicinity zone. If parts of an electrical installation in the vicinity zone of the work location cannot be disconnected, additional precautions must be taken before work starts. In this case use insulating protective



shutters or covering material as protection against accidental contact. The hazard area should be marked for clarity.

2.7 Battery Handling

Lithium-Ion rechargeable batteries require routine maintenance and care in their use and handling. Do not leave batteries unused for extended periods of time, either in the product or in storage. When a battery has been unused for 3 months, check the charge status and charge or dispose of the battery as appropriate.

Please especially consider the following points for storing the device:

- Charge the battery more than 50% of capacity before storage.
- Charge the battery more than 50% of capacity at least once every three months.
- Store the battery at temperatures between 5 °C and 20 °C (41 °F and 68 °F).
- Use the battery in ambient temperature range from 0°C to 50°C.
- The battery self-discharges during storage. Higher temperatures (above 20 °C or 68 °F) reduce the battery storage life.
- The life of the battery pack (when capacity is > 60% of initial capacity) is >500 charge-discharge cycles depending on the conditions of use.



If you will not use the instrument for longer time, always switch the Power button to OFF (bottom position). This enables the maximal power saving mode and will protect your battery of being over-discharged. Over-discharge of Li-Ion batteries has huge influence on their lifetime.



Position	Function
Right	Start (push switch)
Middle	ON after start or standby (returns to this position after push)
Left	OFF (MAX. power saving mode, useful for long term device storage)

If you start the instrument after over-discharge or you didn't use it for a long time, the instrument may take several minutes to start up (even if the fans are active). The integrated PC will start operation not before battery charge level will reach nominal operating conditions.

When the battery pack is used, then the instrument turns off automatically when the capacity drops. Leaving the instrument in this stage for a long time may lead to over discharge so be sure to turn off the power switch on the instrument.



Be sure to observe the following precautions. Incorrect handling may result in liquid leaks, heat generation, ignition, bursting and other hazards.

- The battery pack contains lye, which may cause blindness if it comes to contact with the eyes. Should battery liquid get into your eyes, avoid rubbing them. Flush them with water and seek immediate medical attention.
- When storing the instrument, make sure no objects that could short-circuit the connectors are placed near them.
- If the battery pack fails to finish charging within the stipulated time, disconnect the aC adapter to stop charging and contact NEO Messtechnik.
- Consult NEO Messtechnik or a sales partner in case liquid leaks, strange odor, heat, discoloration, deformation and other abnormalities conditions occur during use, charging or storage. Should these conditions occur during use or charging, turn off and disconnect the instrument immediately.
- Don't expose the instrument to water and don't use it excessively humid locations or locations exposed to rain.
- Don't expose the instrument to strong impacts and do not throw it around.

Recharging a Deeply Discharged Battery

If the unit is not used for a certain period and the Power Switch is not turned to the OFF position, the battery will continue to discharge. It is therefore recommended that the instrument be switched OFF when not in use for some time. However, there is a possibility to recharge a deeply discharged battery again with a special charging mode.

Step 1:

As shown on the right side, switch OFF the unit.

Step 2:

Connect the power cable.

Step 3:

Charge it in this position for approximately 5 hours.

Step 4:

Switch System ON

The system may not operate immediately after complete discharge.

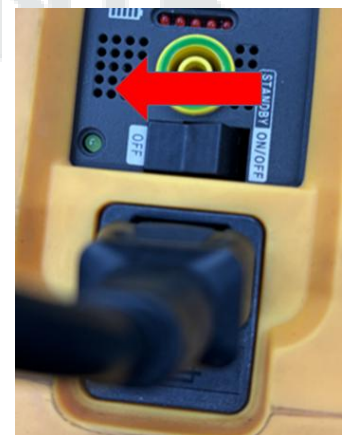



2.8 Cleaning of the device

Before cleaning, all cables must be disconnected and any connection to the power supply or other devices must be disconnected. Do not clean the device with alcohol or other organic solvents. Only use a soft, lint-free, dry cloth for cleaning. When cleaning, make absolutely sure that no liquid gets into the inside of the device. This could cause a short circuit and destroy the appliance or pose a danger to persons.

2.9 Warranty

The warranty for the instrument is 2 years – usual operating conditions preconditioned. This warranty does not cover wear parts, fuses, batteries and accumulators. NEO Messtechnik warrant that at the time of delivery NEO Messtechnik products are free from manufacturing or material defects which might considerably reduce their value or usability. This warranty is not applicable to faults in the software supplied. During the period of warranty, NEO Messtechnik agree to repair faulty parts or replace them with new parts or parts as new according to their choice. Each measure to remedy a claim under warranty shall exclusively be carried out by NEO Messtechnik or an authorized service partner. NEO Messtechnik reject all further claims under warranty, in particular those from consequential damage. Each component and product replaced in accordance with this warranty becomes the property of NEO Messtechnik.

This warranty does not apply to any fault or damage caused by exposing a product to conditions not in accordance with this specification, by storing, transporting, or using it improperly, or having it serviced or installed by a workshop not authorized by NEO Messtechnik.

ATTENTION If the appliance is shipped, the original foam inserts must be used. The switch must be in the "Off" position and secured against being switched on again. Otherwise, the warranty will be invalidated in both cases.

If the appliance is switched on unintentionally, it may overheat and cause damage. The following pictures illustrate how to prepare the device for shipping correctly:

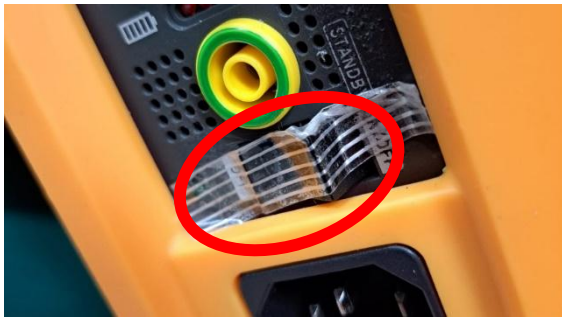

2.10 Recycling

- This is an electronic instrument and must be recycled according to the WEEE – directive. Do not throw away.
- More information see:
http://ec.europa.eu/environment/waste/wEEE/index_en.htm
- Dispose of the test set in accordance with the legal environmental regulations in the country.



2.11 CE Conformity

- This instrument is compliant with the CE - requirements.
- **EMC Directive 2014/30/EU**
- **Test Procedure:**
 - EN 55011: 2009 + A1:2010(Group 1), Class A
 - EN 61326-1: 2013
 - EN 61000-3-2: 2014
 - EN 61000-3-3: 2013
- **EMI (EN55011):**
 - Conducted Emission (CE)
 - Radiated Emission (RE)





- **EMS (EN61000-4-2 ~ 11):**
 - Electrostatic discharge (ESD: EN61000-4-2)
 - Radiated RF immunity (RS: EN61000-4-3)
 - Electrical Fast Transient/BURST (EFT: EN61000-4-4)
 - Surge (Surge: EN61000-4-5)
 - Conducted RF immunity (CS: EN61000-4-6)
 - Voltage dip/interruption (DIP: EN61000-4-8/11)
- **Safety: EN 61010-1: 2010**

Note about Radiated Emissions:

The device is intended for operation in the industrial segment in accordance with EN55011 – CLASS A. When used at private houses it could cause interference with other equipment (such as the radio or television). The radiation level complies with the limit curve A (industrial area). If the living area is sufficiently far away from the planned area of operation (industrial area), equipment there will not be impaired.

2.12 RoHS

- This product is compliant with the RoHS - Directive.
- For further information see:
http://ec.europa.eu/environment/waste/rohs_eee/index_en.htm

2.13 Electrical Units

SI units are always used in this manual.

pico	p	10 ⁻¹²	1pF = 10 ⁻¹² F
nano	n	10 ⁻⁹	1nA = 10 ⁻⁹ A
micro	μ	10 ⁻⁶	1μA = 10 ⁻⁶ A
milli	m	10 ⁻³	1mA = 10 ⁻³ A
kilo	k	10 ³	1kΩ = 1000Ω
mega	M	10 ⁶	1MHz = 10 ⁶ Hz
giga	G	10 ⁹	1GHz = 10 ⁹ Hz

2.14 Environmental and Others

- Use instrument only for indoor use
- Altitude up to 2 000 m;
- Ambient temperature from 0 °C to 50 °C;



- Protection IP 20 / Protection Class II
- CAT IV 600V / Pollution Degree 2 respective / CAT III 1000V / Pollution Degree 2
- Maximum relative humidity 80 % at temperatures up to 31 °C, decreasing linearly up to 50 % relative humidity at 40 °C and linearly decreasing to 20 % relative humidity at 50 °C;
- Fluctuations of the mains supply voltage up to ± 10 % of the nominal voltage;
- Only use the auxiliary equipment provided
- Only use the cables provided
- Always use safety test leads (CAT III 1000V / CAT IV 600V) with full isolated plugs
- Don't connect the instrument to any other power supply or any other device. It is only intended to be used with PQA8000H instrument.





3 Hardware

This chapter describes all the hardware features, like connector, ports and support stand.

3.1 Instrument

There are 2 banana connectors for IV curve and voltage measurement, one banana connector for ground connection and one ODU connector for Current Inputs on the top plate. Furthermore, there is one ODU connector for the sensor box, providing the PV Master with the temperature and solar irradiation data.

On the right side of the case are three fans for internal heat controlling.

Sunlight readable multi-touch LCD on the front side.



Device support and handle are on the rear side mounted. In addition, you can operate the touch screen with a touch pen located on the top of the back.

On the left side of the case are the computer interface, GPS antenna connector, battery indicator LED, power on/off switch and AC power inlet.



3.2 Power ON/OFF Switch

The Power ON/OFF switch is located on the left side on the bottom and has the following three functions, depending on its position.



Position	Function
Top	Start (push switch)
Middle	ON after start or standby (returns to this position after push)
Bottom	OFF (MAX. power saving mode, useful for long term device storage)

3.3 Connector Pins

All the connector pins for measurements are located on the top side.

2 banana connectors for IV-curve and voltage measurement are on the very left (red and black PV). The ODU connector on the left (SENSOR) is for the external sensor box. The banana connector for the ground (FGND) on the left side is used for the leakage measurement of the plant. The last ODU Sensor on the right side is for connecting a current clamp. The status LED on the upper right side shows the measurement status, it's blinking while measuring. Next to the status LED there is the GPS antenna for location tracking.

RED = PV +

BLACK = PV -

YELLOW/GREEN = Ground (Frame Ground PV panel)





3.3.1 Voltage and IV-curve measurement inputs

The device has banana connectors on its top side for measuring a Voltage input signal or the IV-curve for one string (extendable with the extension box) up to 1500V. Combined with the extension box it is possible to connect 20 strings at the same time, each of those strings can have the maximum of 1500V.



Pin	Signal
Red	String V+
Black	String V-

3.3.2 Sensorbox Input

The sensor box is connected to the SENSOR connector. This allows the PV Master to get temperature and solar irradiance data to create the correct IV-curve comparison.

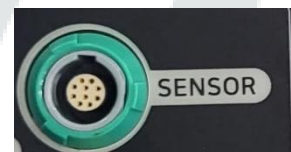

3.3.3 Ground connector

The green-yellow connector FGND is used for the leakage measurement to connect to the ground of the PV plant. It is important to connect the clamp to a blank spot without varnish insulation.



Example 1 - Ground-mounted PV system

In this example the ground is connected to the equipotential bonding of the plant via alligator clip.





Example 2 – Rooftop- mounted PV system

For rooftop mounted systems it is often best to connect the ground to the mounting of the plant like in the picture on the right.



3.3.4 Current Input

For current measurement it is possible to either connect a Rogowski (2V_p max.) coil or a current clamp (10V_p max.) to the clamp connector.



10pin ODU connector

Current sensors like Clamps, Rogowski-coils and other current sensors can be connected using the following pin assignment.



Pin	PV Master
1	Signal +
2	Signal- / GND
3	FGND
4	Rogowski +
5	TEDS
6	GND
7	Isolation GND
8	Isolation +9V
9	+15V
10	-15V

3.3.5 WIFI Antenna

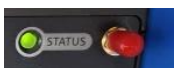

The SMA jack connector is prepared for external WIFI antennas having a SMA plug type connector.

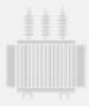

3.4 Sensor box

The PV Master Sensor Box is used to measure weather conditions, specifically ambient temperature and solar irradiance. The unit integrates a pyranometer, an ambient temperature sensor, and a connection interface for a module temperature sensor.

The Sensor Box is available in two versions: Basic and Expert. The Expert version can be customized to meet specific project requirements.

3.4.1 Sensorbox Basic

The Sensor Box Basic is equipped as standard with **one** Class C pyranometer for measuring solar irradiance and two PT100 sensors for measuring ambient and module temperature.

The blue connector is used for the ODU communication cable to the PV Master. In the image on the following page, the blue communication cable is shown on the right-hand side. The two red connectors are intended for connecting the PT100 sensors.

A black protective cap is installed on the pyranometer and must be removed during measurement. It is recommended to always attach this protective cap during transport to protect the sensor.



As shown in the following illustration, the Sensor Box Basic can be mounted to the module frame or the mounting structure using the black bracket. The ball joint allows the box to be aligned at the same tilt angle as the PV modules in relation to the sun.



Installation of the Sensor Box Basic in the yellow design on the photovoltaic module:



Mounting bracket for the Sensor Box Basic, including ball joint:



The Sensor Box Basic also allows the use of either PT100 or PT1000 temperature sensors, with PT100 sensors supplied as standard.



3.4.2 Sensorbox Expert

Within the Sensor Box Expert product line, NEO Messtechnik offers three different variants: the Sensor Box Expert 2, the Sensor Box Expert 5, and the Sensor Box Expert Wireless. All Expert Sensor Boxes are equipped with a touchscreen display, a Wi-Fi antenna, two pyranometer inputs, and either two or five temperature inputs.

The primary advantage of the Expert product line is its wireless communication with the PV Master. Simply position the Sensor Box Expert in direct sunlight, including the module temperature sensor, while you can move freely and wirelessly to the inverter with the PV Master. The measured irradiance and module temperature are transmitted wirelessly and seamlessly to the measuring device.

Each version of our Sensor Boxes offers specific advantages. The number of sensor inputs and the required accessories can be individually customized according to your requirements.



Sensorbox Expert 2:

When selecting the Sensor Box Expert, you have the option to connect two solar irradiance sensors, enabling the testing of **bifacial modules** or strings.

You can also choose between Type K thermocouple, PT100, or PT1000 temperature sensors, depending on your measurement requirements.

- PY2TCK2 (2x pyranometer, 2x thermocouple type K)
- PY2PTH2 (2x pyranometer, 2x PT100)
- PY2PTT2 (2x pyranometer, 2x PT1000)



Sensorbox Expert 5:

Depending on your specific application, we also offer versions with up to five temperature inputs.

- PY2TCK5 (2x pyranometer, 5x thermocouple type K)
- PY2PTH5 (2x pyranometer, 5x PT100)
- PY2PTT5 (2x pyranometer, 5x PT1000)

Sensorbox Wireless

With the Sensor Box Expert Wireless, the temperature sensor can be replaced by a wireless temperature sensor, providing maximum flexibility during measurements.

It is important to note that all Sensor Boxes within the Expert product line feature a wireless Wi-Fi connection to the PV Master measuring device.

Solar radiation measurement:

Solar irradiance can be measured using any type of pyranometer or reference cell. The Sensor Box Expert product line is equipped with two inputs for solar irradiance measurement, enabling accurate measurements on **bifacial PV modules**.

Irradiance sensors can be ordered directly as part of a complete set from NEO Messtechnik. Depending on the required level of accuracy, we offer Class A, B, and C pyranometers.



ISO 9060:1990 standards

Pyranometer Specifications	Spectrally Flat Class A	Spectrally Flat Class B	Spectrally Flat Class C
Response time (95% response)	< 15 s	< 30s	< 60s
Zero off-set (a) Response to 200 W/m ² net thermal radiation (ventilated) (b) Response 5 K/hr change in ambient temperature	± 7 W/m ² ± 2 W/m ²	± 15 W/m ² ± 4 W/m ²	± 30 W/m ² ± 8 W/m ²
Non-stability (change per year, percentage of full scale)	± 0.8 %	± 1.5 %	± 3.0 %
Non-linearity (percentage deviation from the responsivity at 500 W/m ² due to any change of irradiance within the range 100 to 1000 W/m ²)	± 0.5 %	± 1 %	± 3 %
Directional response for beam radiation (The range of errors caused by assuming that the normal incidence responsivity is valid for all directions when measuring, from any direction, beam radiation whose normal incidence irradiance is 1000 W/m ² Commonly defined as up to 80° zenith angle.	± 10 W/m ²	± 20 W/m ²	± 30 W/m ²



3.4.3 Install Environmental sensors

Connect the pyranometer, ambient temperature, and module temperature sensors and mount them, for example, as shown in the illustrations below.

The following figure shows the installation of the Sensor Box Basic, mounted using the bracket with integrated ball joint.

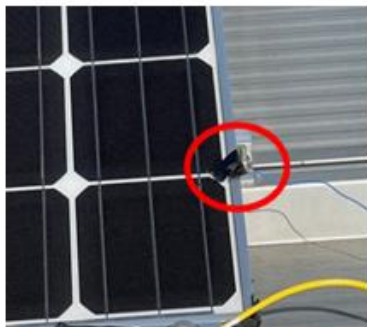
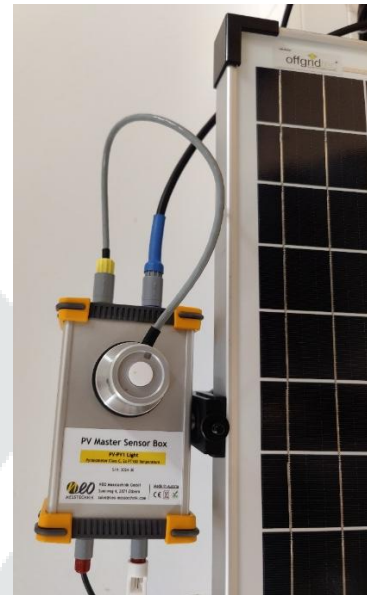

Thermal couple attached on photovoltaic module

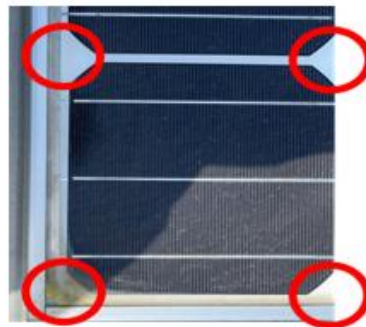

Thermal couple attachable position



Thermal couple on the back of photovoltaic module

The following figure shows the installation of the Sensor Box Expert. For mounting on the PV module, use either the red and black plastic mounting clamps or the silver metal mounting clamps. In the image, the metal clamp is shown on the left and the plastic clamp on the right.



If you are using two pyranometers for bifacial modules, please ensure that the sensor for front-side irradiance is not swapped with the sensor for rear-side irradiance. Please refer to the labeling for correct assignment.

MESSTECHNIK



3.5 Extension box PM10-EXT-20CH

With the PM10-EXT-20CH extension box, the measuring time can be shortened considerably, as up to 20 strings can be connected simultaneously, with each individual string having a maximum current of 30A and a maximum voltage of 1500V. To do this, the extension box must be connected to the PV master at the bottom right ports. The sensor box is connected to the bottom left of the box. A more detailed connection diagram is provided in chapter 4 Connection instructions. The connector "- COM" is the common negative pole which connects all negative poles of the individual channels within the box.



IMPORTANT!

For the leakage measurement the common ground cannot be used.



3.6 Connection cable for PV+

The connecting cable between PV+ of the extension box and PV+ of the PV master or between PV+ of the string and PV+ of the PV master is shown in the following picture. This measuring cable contains a 2.5A fuse to protect against overvoltage.



If the 2.5A fuse blows, it can be replaced with a fuse of the same rating by unscrewing the test lead. The following illustration shows how the test lead looks when opened.



Case 1: PM-10

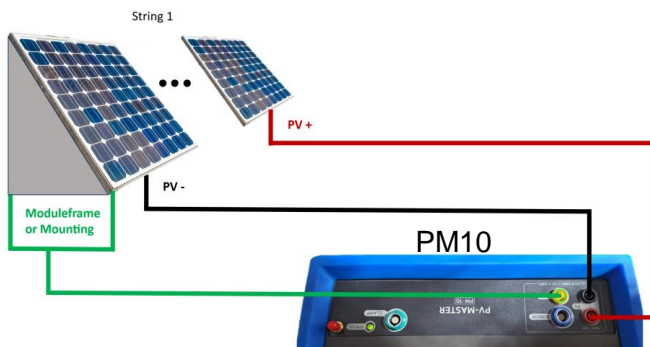

Case 2: PM-10 and PM10-EXT-20CH

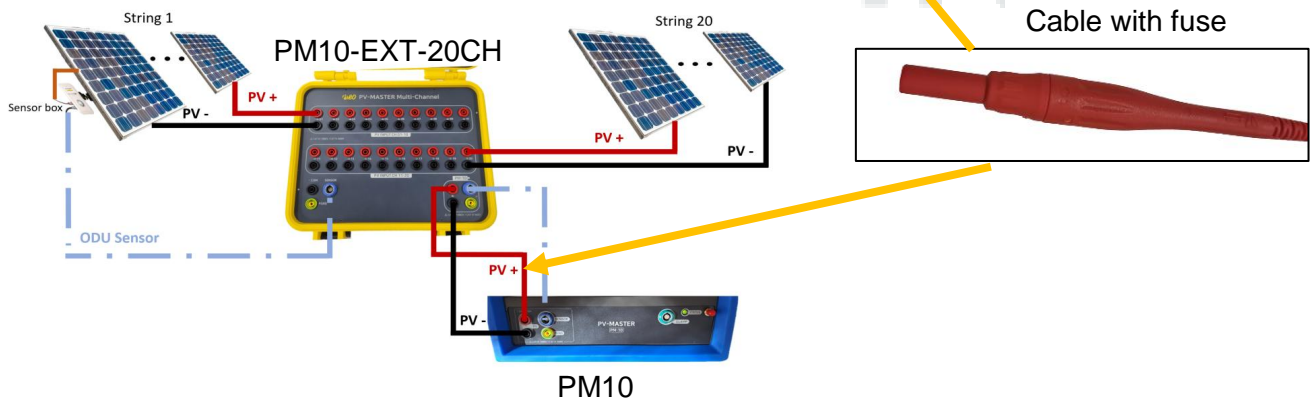



3.6.1 Computer Interface

The computer interfaces are located on the left top side

One 1Gbit Ethernet interface, two USB3.0, one USB2.0 interfaces and one HDMI port for an external monitor.

HDMI Port	
Pin	Signal
1	TMDS data2+
2	TMDS data2 shield
3	TMDS data 2-
4	TMDS data 1+
5	TMDS data1 shield
6	TMDS data 1-
7	TMDS data 0+
8	TMDS data0 shield
9	TMDS data 0-
10	TMDS clock +
11	TMDS clock shield
12	TMDS clock -
13	CEC
14	NC
15	DDC clock
16	DDC data
17	GND
18	+ 5V
19	Plug detected

2 x USB 3.0	
Pin	Signal
1	VCC
2	Data-
3	Data+
4	GND
5	SSRX-
6	SSRX+
7	GND Drain
8	SSTX-
9	SSTX+



1 GB LAN	
Pin	Signal
1	BI_DA+
2	BI_DA-
3	BI_DB+
4	BI_DC+
5	BI_DC-
6	BI_DB-
7	BI_DD+
8	BI_DD-

USB 2.0	
Pin	Signal
1	VCC
2	Data-
3	Data+
4	GND



3.6.2 Battery indicator LED



NO. of ON LED	Remaining battery
5	80~100%
4	60~80%
3	40~60%
2	20~40%
1	0~20%

3.6.3 Fan

Three Fans for internal heat control are located on the right side. Two fans input the cold air, while the third outputs the internal warm air. The speed of the fans is controlled depending on the internal temperature. Additionally, metal mesh filters out the external dust particles.



3.6.4 Terms and definitions

PV:

The abbreviation PV stands for Photovoltaic

STC conditions:

For photovoltaic systems, STC conditions typically refer to Standard Test Conditions. These conditions are used to specify the testing environment for assessing the performance of solar panels or photovoltaic modules. STC conditions include:

Irradiance: Standard Test Conditions specify a solar irradiance level of 1000 watts per square meter (W/m^2) to simulate sunlight intensity.

Temperature:

The cell temperature during testing is set at 25 degrees Celsius (77 degrees Fahrenheit) to standardize the performance evaluation.

Air Mass: STC assumes an air mass of 1.5, which represents the path length of sunlight through the Earth's atmosphere.



V_{OC} – Open circuit voltage

The open-circuit voltage (V_{OC}) in a photovoltaic system refers to the maximum voltage a solar panel/string can produce when there's no load attached to it (i.e., no current is flowing). It represents the potential difference across the terminals of the solar panel/string when there's no external circuit connected, allowing electrons to move freely within the cell.

I_{SC} – Short circuit current

The short-circuit current (I_{SC}) in a photovoltaic system represents the maximum current that flows through a solar panel/string when the circuit is shorted, creating a zero-resistance path across its terminals. This condition occurs when the positive and negative terminals of the solar panel/string are directly connected without any load in the circuit.

V_{MPP} – Maximum power point voltage

V_{MPP} (Maximum Power Point Voltage) in photovoltaics refers to the voltage at which a solar panel/string generates its maximum power output. It represents the specific voltage level at which the solar module/string operates most efficiently to produce the highest amount of electrical power while considering varying sunlight conditions and temperature.

I_{MPP} – Maximum power point current

I_{MPP} (Maximum Power Point Current) in photovoltaics refers to the highest current a solar panel/string can produce at its maximum power output. It represents the optimal current level that the solar module/string generates when operating at the Maximum Power Point (MPP), where the panel generates the most electricity under specific conditions of sunlight intensity and temperature.

IV-curve

The IV (current-voltage) curve in photovoltaics illustrates the relationship between the current (I) and voltage (V) output of a solar panel/string under varying conditions of sunlight intensity and temperature. It represents the electrical characteristics of the solar device.

4 Connection instructions

This section describes how the PV Master is connected to the components of the PV system and linked to the sensors and accessories of the PV Master. Please follow these instructions



exactly to avoid damage to the appliance or personal injury. If you have any further questions or uncertainties, please contact the NEO Messtechnik information hotline.

4.1 Single channel leakage measurement

The following figure shows the measurement setup for leakage measurement of a single channel (string) using the PV Master. No accessories (sensor box, extension box) are required for leakage measurement apart from the measuring cables and the pick-up tips/clamps. As described in chapter 3.3.3, the earth connection can be established either via the mounting of the system or the module frame. Then the positive and negative cables of the PV string need to be connected to the PV master.

Measurement principle

The device measures the two input voltages PV (+) and PV (-) in relation to earth and determines the suspected position of the fault in the string from the ratio of the voltages to each other.

Requirements

The Distance to Fault function provides correct results under the following conditions:

- Test on a single string disconnected from the inverter, disconnected from all dischargers
- Single fault of low insulation at any position in the string
- Insulation resistance of the single fault $< 0.1 \text{ M}\Omega$
- Due to the random nature of these faults, it is recommended to carry out the measurements under ambient conditions similar to those in which the fault was reported

IMPORTANT!



Before this connection can be made, however, the load must be disconnected from the system (switch off the DC switch). It must be ensured that no power is generated by the photovoltaic system anymore and that the DC current is zero. Otherwise, danger to human beings or the measurement instrument is caused. For this purpose, we recommend using a **Direct Current (DC) - Clamp Amperemeter!**

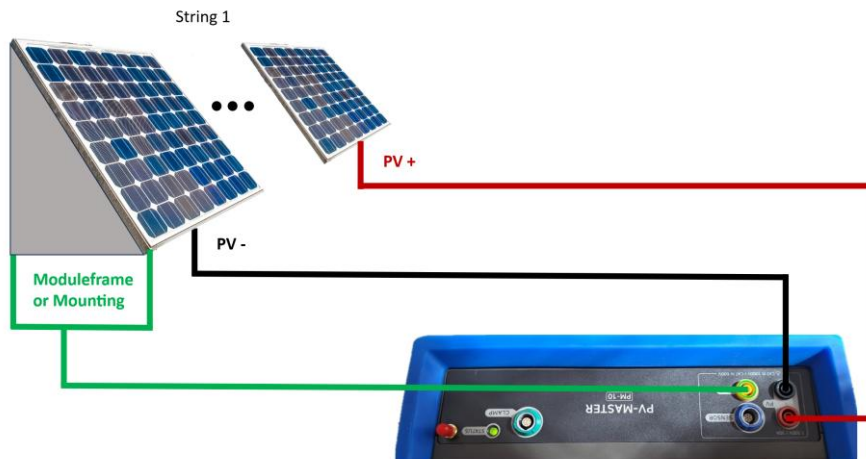

IMPORTANT!

For the Leakage measurement, a good system earthing must be ensured. In the case of open earth, for example, the results could be falsified as the real reference potential does not exist.

4.2 Single channel IV-curve measurement

For single-channel IV curve measurement, only the sensor box needs to be connected to the module frame or the rails of the system. The plus and minus cables can be taken directly from the leakage measurement. The temperature sensor must be positioned on the module in such a way that none of the cells are shaded by the sensor.



IMPORTANT!

The sensor box must be aligned in the same orientation to the sun as the photovoltaic modules are positioned.

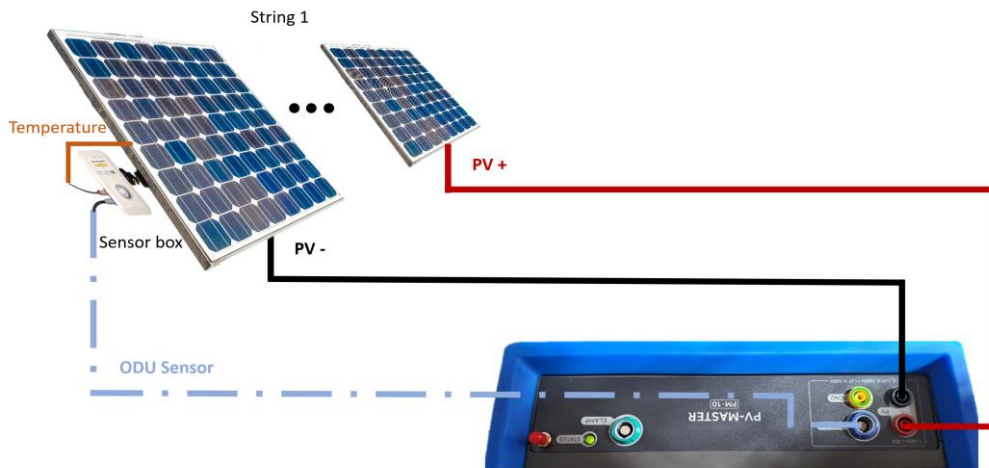

IMPORTANT!

Always use the PV+ cable with the integrated fuse as mentioned in chapter 3.6 for safety and protection.

The following minimal conditions have to be met to be able to measure an IV-curve

PM-10: IV-Curve min. $U_{oc}=10V$

PV-MULTI20 Version 2 (2024): IV-Curve min. $U_{oc}>50 V$

4.2.1 Additional safety / protection check

If the voltage of the measured signal is not stable, an error message will appear “PEAK NOISE DETECTED” and the measurement will not be executed. This is an additional protection mechanism to protect instrument and operators. Reason for this might be not good contact of voltage cable or a severe issue on the PV line.

The protection algorithm monitors the voltage over some time and if the following limit values are exceeded, no measurement will be executed.

- $>10V$ at range: 0-400V
- $>2\%$ at range 400V to 1600V

This is a unique key feature other vendors often not provide but what increases safety of instrument and operator.



4.3 Multichannel leakage measurement

To measure several strings simultaneously, the extension box is connected to the PV master. To do this, the Ground, PV+ and PV- connectors are connected to the respective connector. The strings can then be connected to the inputs of the extension box. Up to 20 strings can be connected for one measurement. The inputs to be used can be selected in the software.

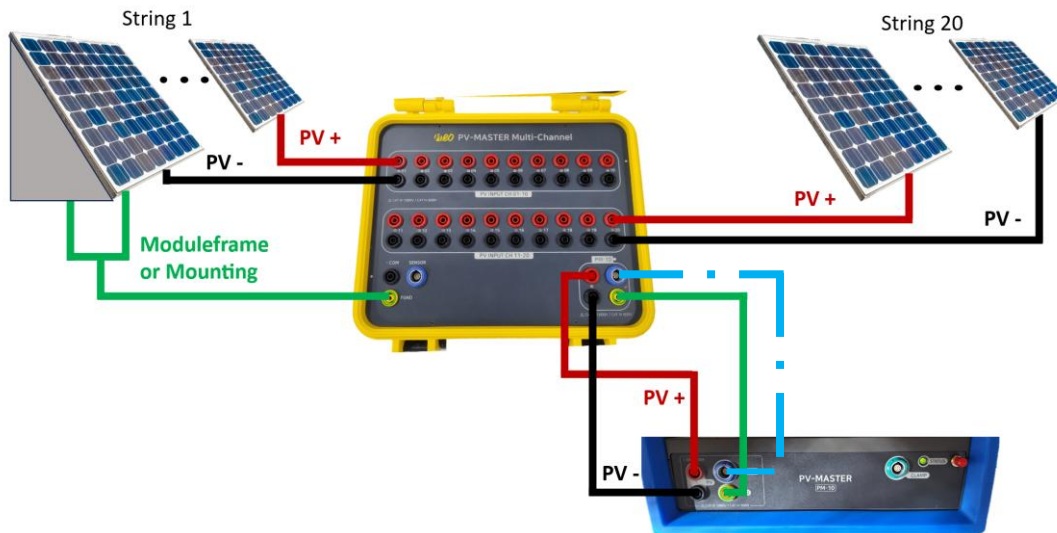

IMPORTANT!

Always use the PV+ cable with the integrated fuse between PV Master and Extension box as mentioned in chapter 3.6 for safety and



4.4 Multichannel IV-curve measurement

For the subsequent IV-curve measurement, only the sensor box needs to be installed on the module frames or rails. Otherwise, the procedure is the same as for the leakage measurement (except that the ground connection is not required).

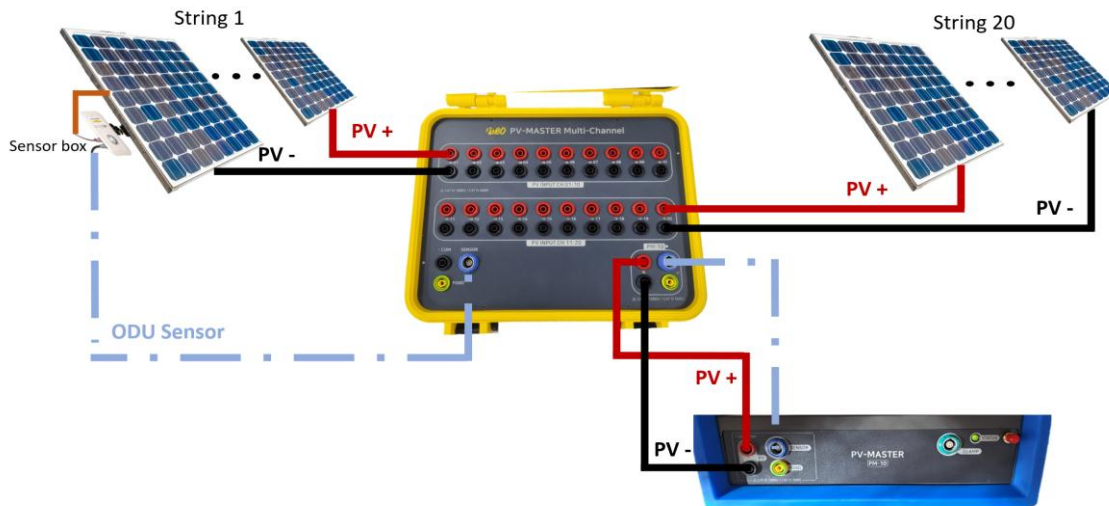

IMPORTANT!

Always use the PV+ cable with the integrated fuse between PV Master and extension box as mentioned in chapter 3.6 for safety and

MESSTECHNIK



4.5 Multichannel IV-curve measurement using common minus

If there is a common negative pole in the generator connection box, this can also be connected directly to the common negative of the extension box. This saves having to connect each negative pole of the individual strings.

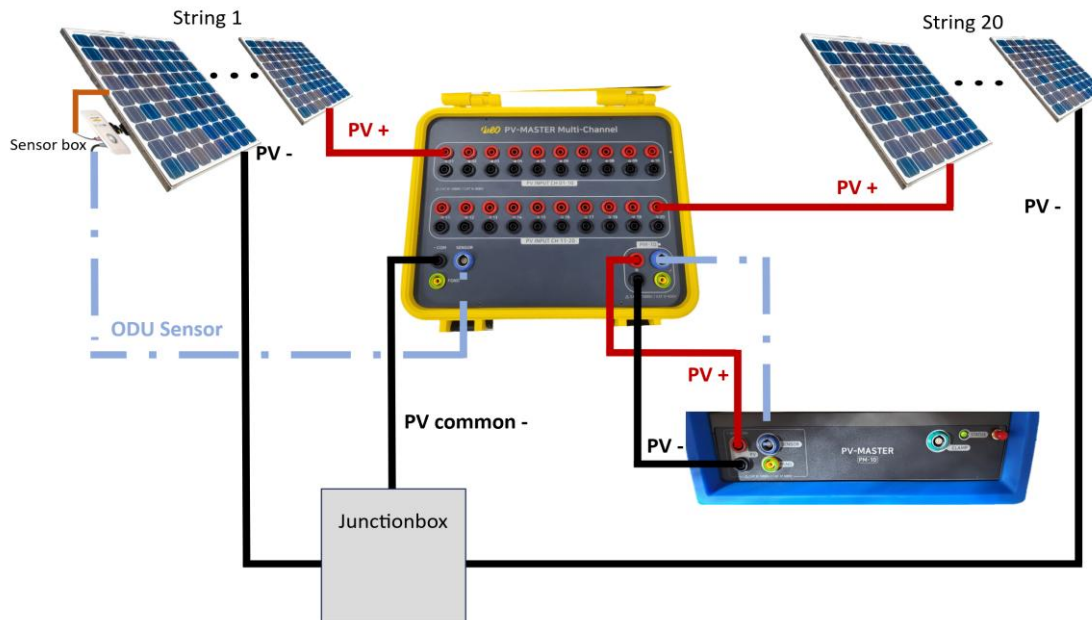

IMPORTANT!

Always use the PV+ cable with the integrated fuse between PV Master and extension box as mentioned in chapter 3.6 for safety and



4.6 Connecting the PM-10

For the connection of the PM-10 to the string or the PM10-EXT-20CH always use the red cable with the integrated fuse for protection as in the following cases:

Case 1: Connection to the string directly

Case 2: Connection to the PM10-EXT-20CH

Case 1: PM-10

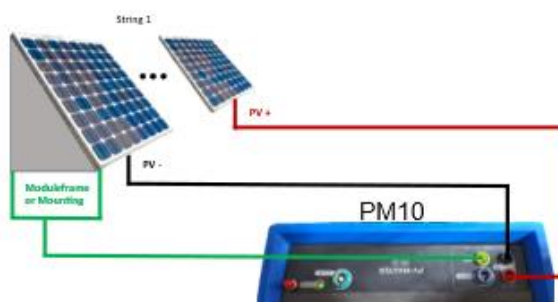

Case 2: PM-10 and PM10-EXT-20CH

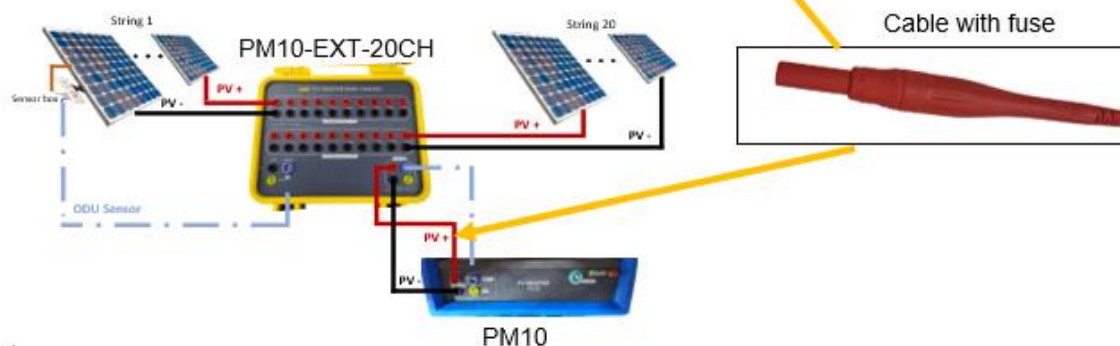

IMPORTANT!

Always use the PV+ cable with the integrated fuse as mentioned in chapter 3.6 for safety and protection.



5 Software



The measurement software is included with the device.

5.1 Desktop of PV Master

After starting the PV Master, you will automatically be taken to the device's desktop. You will see the "NEO Updater PV" icon in the upper right corner.

Please double-click on the icon.

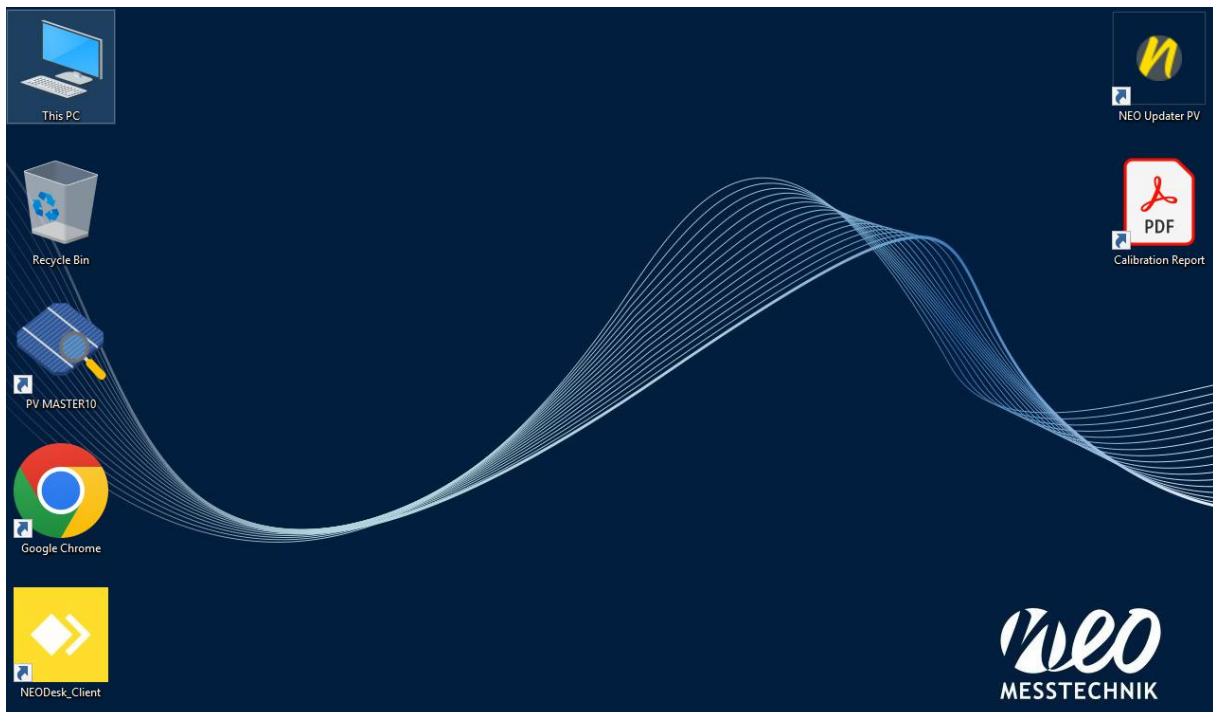



If a new software version from NEO Messtechnik is available, you can click on the download icon here.

Software	Quick-Start Manual	Product Manual	Update	Running
PV Master PQ Data Acquisition Software				Not Active
				Not Active
				Not Active
				Not Active
				Not Active
NEODesk Support Remote Client				Active

Useful Links
[Video Overview](#)
[Download Portal](#)
[PV Master Report](#)

Contact
<https://www.neo-messtechnik.com>
support@neo-messtechnik.com
[Contact Partner](#)
[LinkedIn](#)
[Youtube](#)
Phone: +43 2642 20301

Afterwards, please click on "Update."

NeoUpdaterPV 1.5.6.1 is available!

A new version of NeoUpdaterPV is available!

NeoUpdaterPV 1.5.6.1 is now available. You have version 1.5.6.0 installed. Would you like to download it now?

Release Notes:

Software Update

Downloading at 4.3 MB/s 26.1 MB / 59.7 MB

Update



Afterwards, click on "Run."

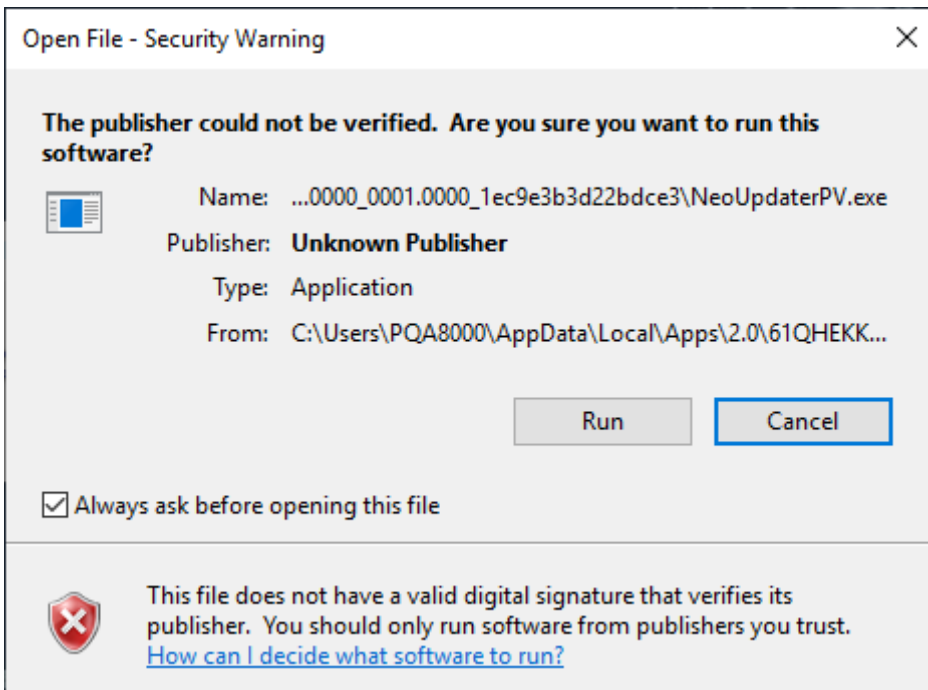

If the green check mark is displayed, the update process was successful. The latest software version is now installed on the device.

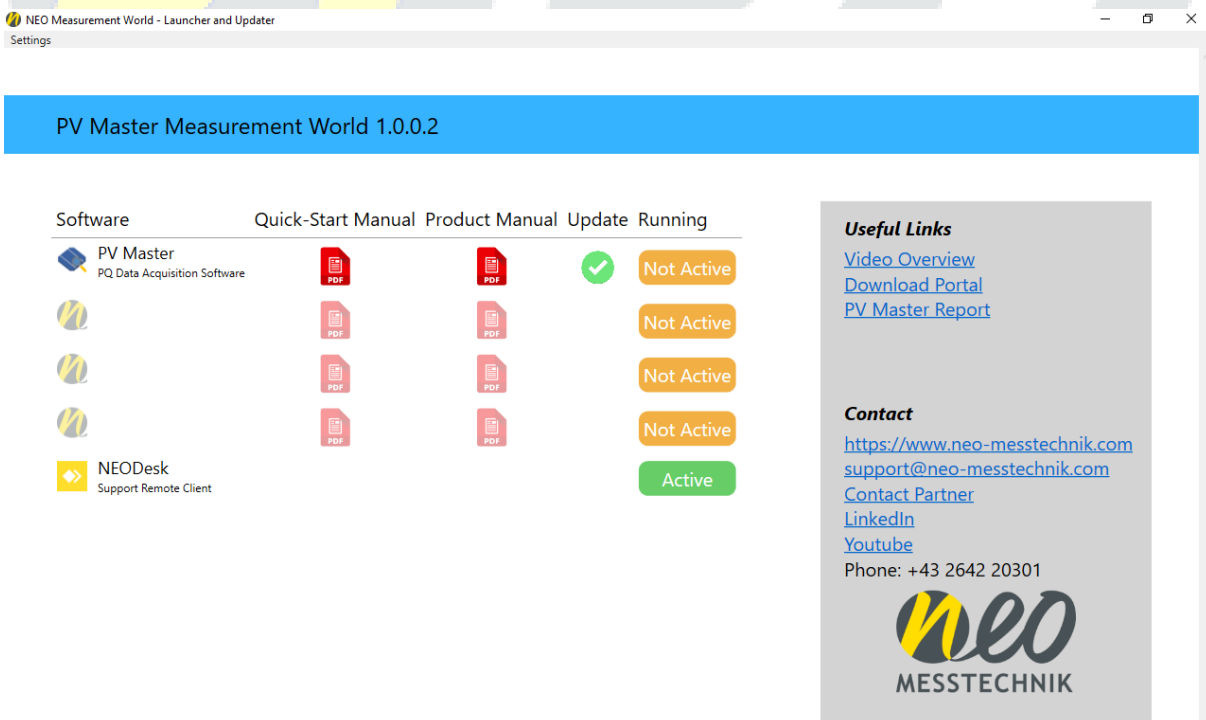



5.2 Start Measurement Software

The measurement software can also be started via the desktop shortcut. If you want to check whether a newer software version is available, click on the “NEO Updater PV” icon as described above.

Note: The instrument always starts-up in the last used configuration (Sampling Rate, connection, range, language etc.)

In the NEO Updater PV, you can also click on the PV Master icon to start the software.

Software

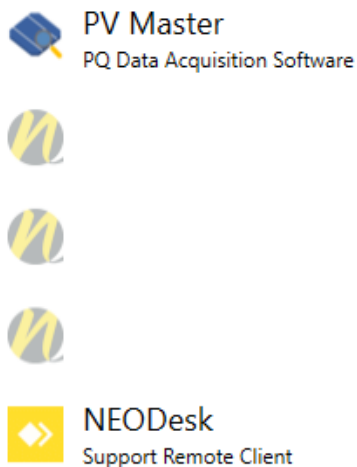

Contact

<https://www.neo-messtechnik.com>
support@neo-messtechnik.com
[Contact Partner](#)
[LinkedIn](#)
[Youtube](#)
Phone: +43 2642 20301



The NEODesk icon is intended to allow a NEO Messtechnik support technician to establish a remote desktop connection to the device. For this purpose, the device must be connected to the internet, for example via a Wi-Fi hotspot on your mobile phone.

If you experience any issues with our products, please contact the support hotline at **+43 2642 20301**.



IMPORTANT!

Always use the latest software version for measurements.

The use of outdated software versions below 1.5.6 is not permitted.



To check the software version, click on the icon  in the bottom right corner of the PV Master software.







5.3 Sequencing diagram

The following diagram describes the rough sequence of a measurement with the PV Master

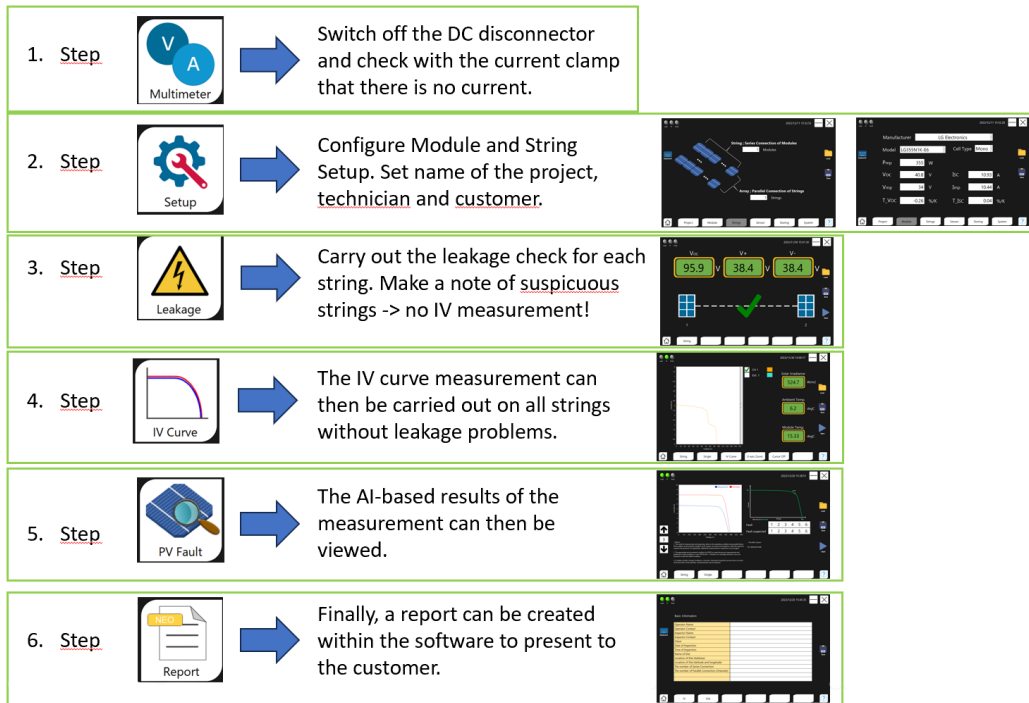
10. You will find the more detailed procedure below.



5.4 Main

When the software is started, the main screen is displayed. It consists of an Auto Mode, the Leakage Measurement, the IV Curve Trace function, the Multimeter, the PV Fault Function, the Reporting Tool and the Setup Mode. The  button can be used to view the saved data of measurements that have already been carried out. This applies to the leakage check, the IV curve measurement and the automatic fault diagnosis. To do this, simply click on load, select the saved file and load it. Depending on which results you want to see, click on Leakage, IV curve or PV fault after loading the file.

Continuous automatic measurements can be carried out using the **auto mode**. If the device has been properly installed with all the required sensors, monitoring can be carried out in this manner.

To rule out any risks, a leakage measurement (Leakage Test) must be performed at the beginning of the measurement. It is used to detect potential insulation faults by indicating whether leakage currents are flowing towards earth potential or whether an impermissible connection exists between earth potential and an active conductor of the string. The "Distance to Fault" function supports troubleshooting by automatically calculating the position of the fault within the string.



Note: The leakage measurement allows the localization of possible insulation faults in the system; however, it does not replace a standard-compliant insulation tester. The insulation resistance in MΩ cannot be measured with the PV Master.

The **IV curve** measurement is the actual performance measurement of the system; the measured curve can be used to determine how much power loss occurs and why.

In **multimeter** mode, the PV Master acts like a multimeter. Irradiation, temperatures, DC currents and DC voltages can be measured.

PV Fault is the AI-based diagnostic function. The artificial intelligence compares the measured curves with a database of faulty curves. This allows the PV Master to determine the causes of faults independently.

Simple measurement reports can be created directly on the PV Master using the **report** function.

All settings can be adjusted under **Setup**.

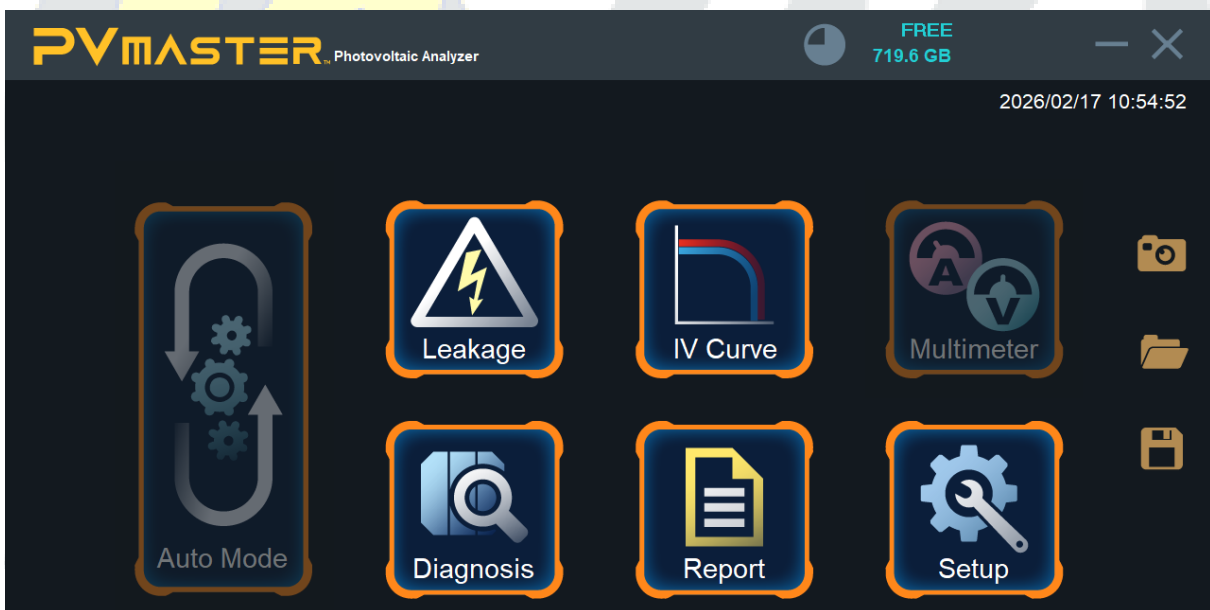

5.5 Setup

5.5.1 Project

When the Setup button is pressed, the Setup Mode is initiated, starting with the Project section. Here, projects, users and setup files can be created, and they can be loaded and saved using the Load and Save options. The filename is automatically generated from the Setup entry. On the left, there is an option to open a screen keyboard. The house symbol on the bottom takes you back to the Main Screen.



5.5.2 Module

In the Modules tab, the module can be configured. You can either load one directly from the database or manually enter data. Retrieve the information from the manufacturer's datasheet.



Temperature coefficient [%/K]	Crystakline Silicon Modules	Heterojunction Silicon Modules	CIGS Modules	CdTe Modules
k_{ISC}	0,04	0,045	0,01	0,04
k_{UOC}	-0,4	-0,3	-0,3	-0,25
k_{PMPP}	-0,4	-0,3	-0,3	-0,25

5.5.3 Strings

In the Strings tab, you can define how many modules are connected in series and how many in parallel. If you only want to measure a single module, select 1 Module Serial and 1 Module Parallel, as shown in the image below. If the strings have different numbers of modules, these would have to be measured separately (with their own setup).

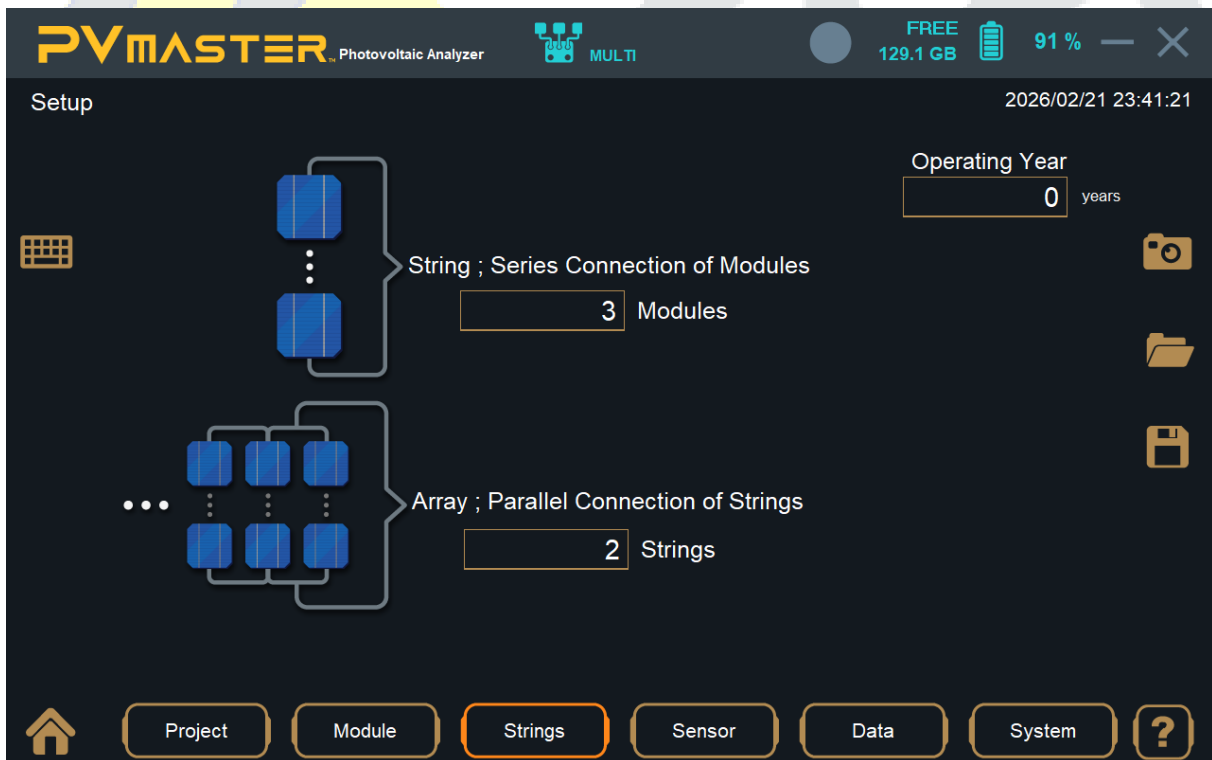

Example:

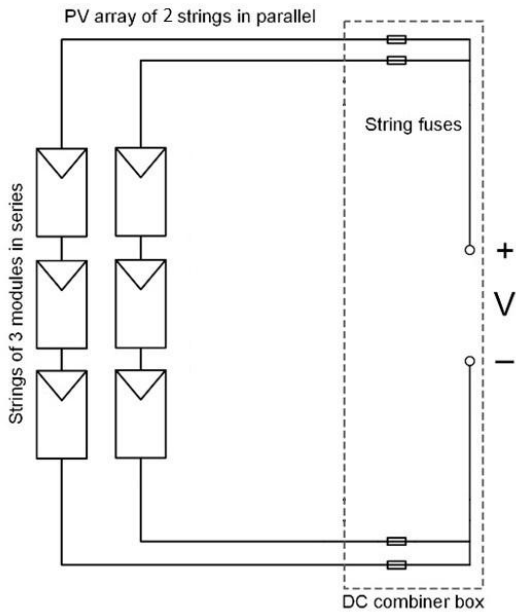

In this example there are 2 strings connected in parallel which meet in the DC combiner box. Each string has 3 modules connected in series. For this example, the number 3 would have to be entered in the software under Modules and the number 2 under Strings.





For most applications where, for example, 22 modules are connected in series in one string and **no parallel string connection is present**, please use the **standard configuration** shown in the **following figure**.

If multiple strings are connected in parallel to a single input of the Extension Box or directly to the PV Master (one positive and one negative terminal), you must enter the number of parallel strings in the field “Array; Parallel Connection of Strings”.

Important: The parallel connection always refers to the number of strings connected to one input (one +/- terminal pair), not to the number of available inputs on the Extension Box. Each input must be considered separately. For example, if two strings are connected in parallel to one single input, the value “2” must be entered, even if the Extension Box has multiple inputs.

In the field “String; Series Connection of Modules”, enter the number of modules connected in series per string (e.g. 22).

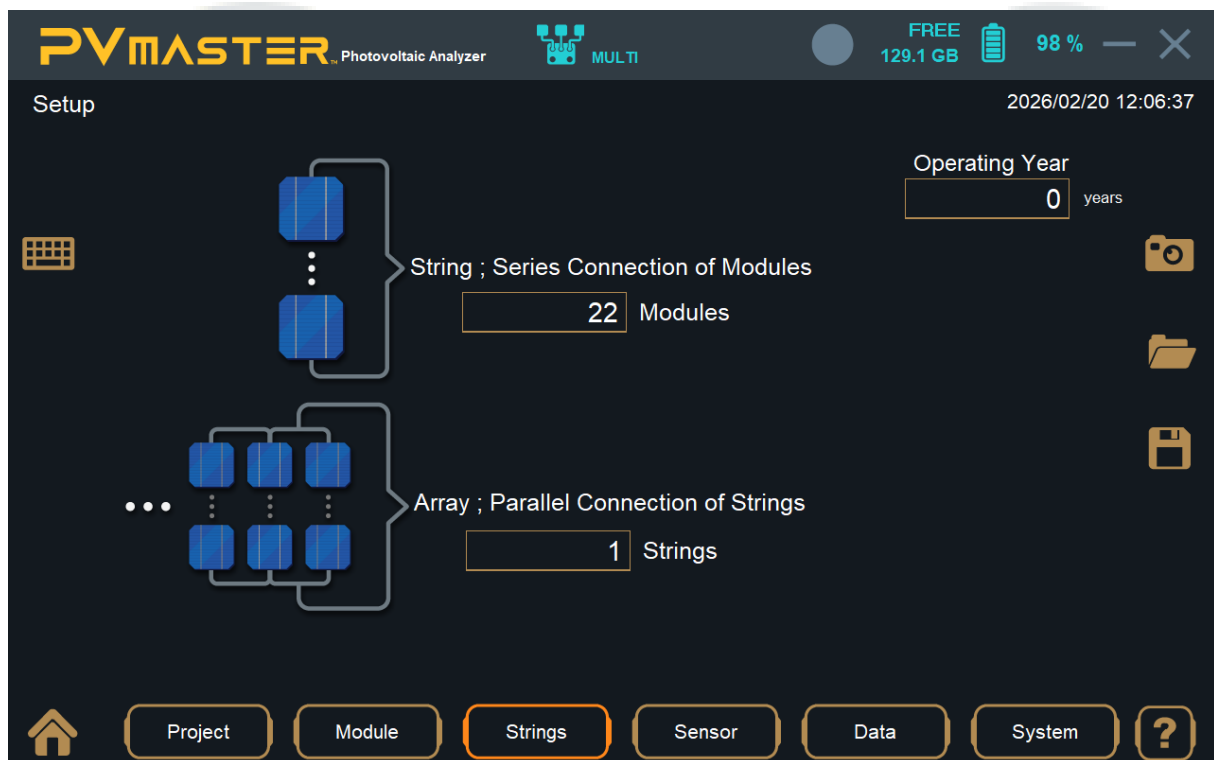

Please strictly observe that the maximum permissible short-circuit current per input of the Extension Box or PV Master is 30 A.

Exceeding this limit can result in severe damage to the measurement electronics, input stages, and internal protection components. An overcurrent condition may lead to permanent destruction of the device and constitutes improper use, which is not covered by the warranty.

Therefore, always verify the expected string short-circuit current in advance, especially when connecting multiple strings in parallel to a single input, to ensure that the 30 A limit is not exceeded.



5.5.4 Sensor

Here you can see an overview of the external sensors that have been connected. You can check whether the connected sensors have been initialized correctly. The PV-Multi window shows the connection status of the extension box. If the extension box is not used, the window can be ignored. In the Solar Irradiance window the scaling of the Pyranometer can be changed. This is not needed if the Sensorbox Basic is used, as the scaling factor is already integrated.

5.5.4.1 Instructions for Sensorbox Basic

After connecting the Sensor Box Basic to the PV Master measuring device using the blue ODU communication cable, or alternatively via the left port of the Extension Box, please start the PV Master software.

Navigate to “Setup” → “Sensor” and click on “Refresh”.

If the Sensor Box Basic is not detected, briefly disconnect the cable connection to the Sensor Box. Then reconnect the Sensor Box to the PV Master measuring device and click “Refresh” again.

After completing the correct setup, click the save icon. 

The connection should now be stable.

To verify the connection, you can check the irradiance under the “Multimeter” menu.



5.5.4.2 Instructions for the Sensorbox Expert

5.5.4.2.1 Preparation

Power on the Sensor Box:

Switch on the Sensor Box using the ON/OFF switch located below SOL1 and SOL2.

Attention: **The Sensor Box should be fully charged before use.**



Wait at least 1 minute for the device to fully boot up.

Close the PV Master software if it is currently open.

Establish a Wi-Fi connection:

→ On the PV Master measuring device, open the Wi-Fi settings in the bottom right corner.

Connect to the Wi-Fi network of the Sensor Box Expert. **Please ensure that the antenna is properly installed on both the PV Master and the Sensor Box Expert.**

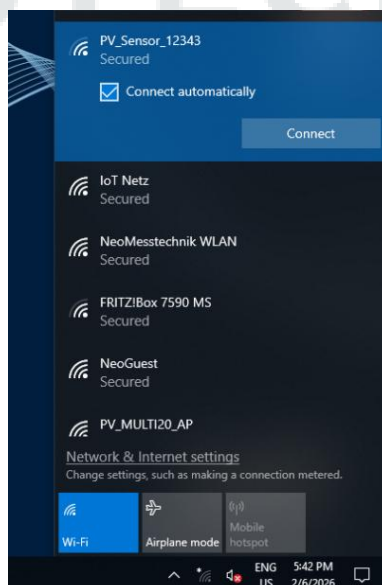



→ Password: 123456789

5.5.4.2.2 Launch PV-Master and Connect the Sensorbox

Start the PV Master software.

Navigate to “Setup” → “Sensor” and click on “Refresh”.

If the correct sensitivity is displayed, the connection has been successfully established. Please compare the sensitivity shown in the software with the sensitivity specified on the pyranometer and ensure that the sensor labels are correctly assigned.



The Sensor Box Expert can be connected either via Wi-Fi or via a wired connection.

For a wired connection, the blue ODU communication cable must be connected between the Sensor Box Expert and the PV Master or, alternatively, the Extension Box.

The cable is plugged into the blue port on the Sensor Box Expert and into the blue port on the PV Master or the blue port on the left side of the Extension Box.



5.5.4.2.3 Assign Sensors

In the lower left corner, you will see a list of the detected sensors under “Sensor Channel”. The respective sensor is selected by ticking the checkbox (✓). Use the large arrow pointing to the right to assign the selected sensor to the desired measurement channel. To set the checkbox, click on the desired sensor (Solar 1, Solar 2, Temp 1 or Temp 2).





Proceed step by step as follows:

1. Tick the checkbox (✓) next to the desired sensor (e.g. Temp1).
2. Click the large arrow pointing to the right and assign the sensor to the appropriate channel (e.g. Ambient – ambient temperature).
3. Then untick the checkbox (✓).
4. Now tick the checkbox for the next sensor (e.g. Solar 1) and click the large arrow pointing to the right again to assign it (e.g. as Solar Irradiance).

Important: The checkbox must be unticked after each assignment and then ticked again for the next sensor.

For bifacial measurements with two pyranometers, tick the checkboxes for Solar 1 and Solar 2 simultaneously and then click the large arrow pointing to the right once to assign both irradiance sensors at the same time.

5.5.4.2.4 Verify Scaling Factor

Ensure that the scaling factor configured in the software matches the value printed on the pyranometer label ($[\mu\text{V}/\text{W}/\text{m}^2]$). If not, you can adjust the value in the software and then click “Save.”





5.5.4.2.5 Save the Setup!



After completing the correct setup, click the save icon.

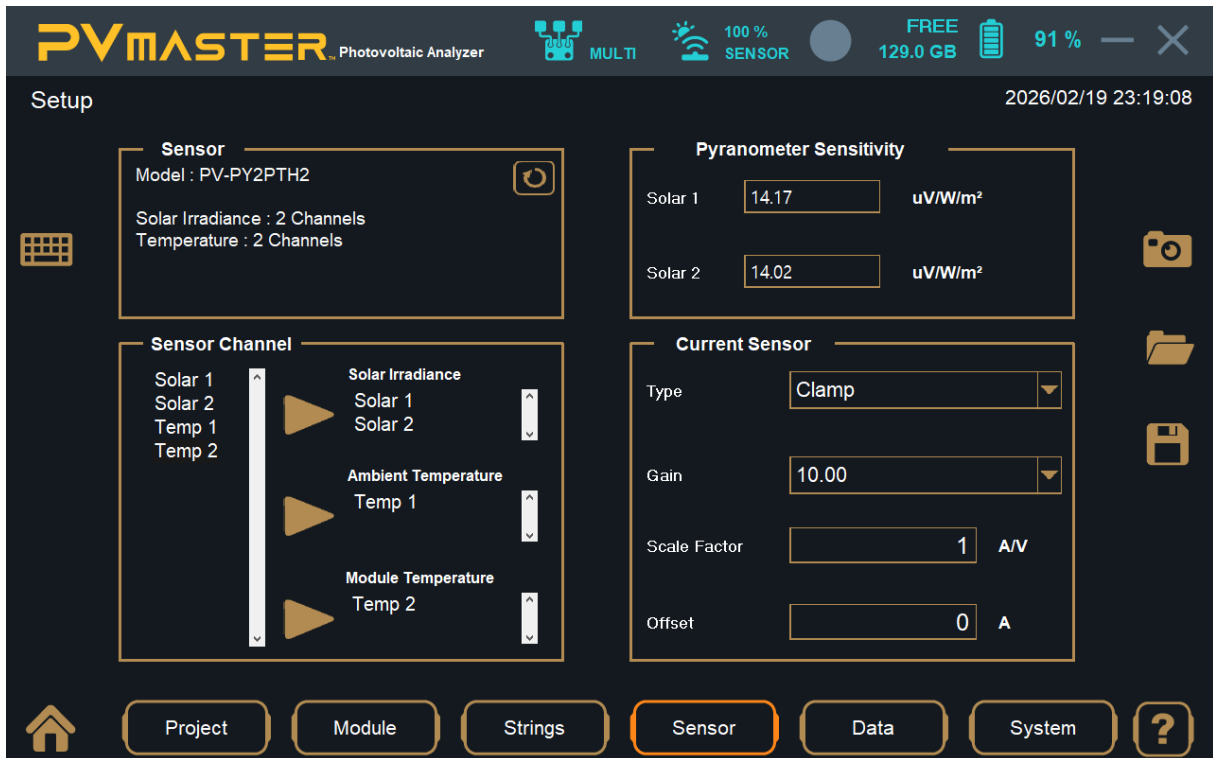



5.5.5 Storing

Here, you can make various settings for both the measurement and the system. You can activate the Automatic Save Mode or you can choose the Manual Mode:

Auto-Save: All executed measurements automatically will be saved

Manual – Save: After measurement the data needs to be saved manually by pressing the following button 

In the System section, you can show or hide the virtual keyboard. You can also change the order in which files are stored under File Format Order.





5.5.6 System

In the System section, you can make settings regarding the measurement, data format, and system. You can choose the sampling rate and define or adjust the Fault Detection Value, with default values being 100000 S/s and 15%. Format settings, such as Decimal Separator, Thousands Separator, Date Order, Date Separator, or Clock Type, can be configured under Format. In the System category, you can customize the language and specify the action when clicking on the X in the software.





5.6 Leakage measurement

When all settings have been configured, the Leakage Measurement can be performed. This can be done optionally for the string or array. To initiate, click on the blue 'Start' button.

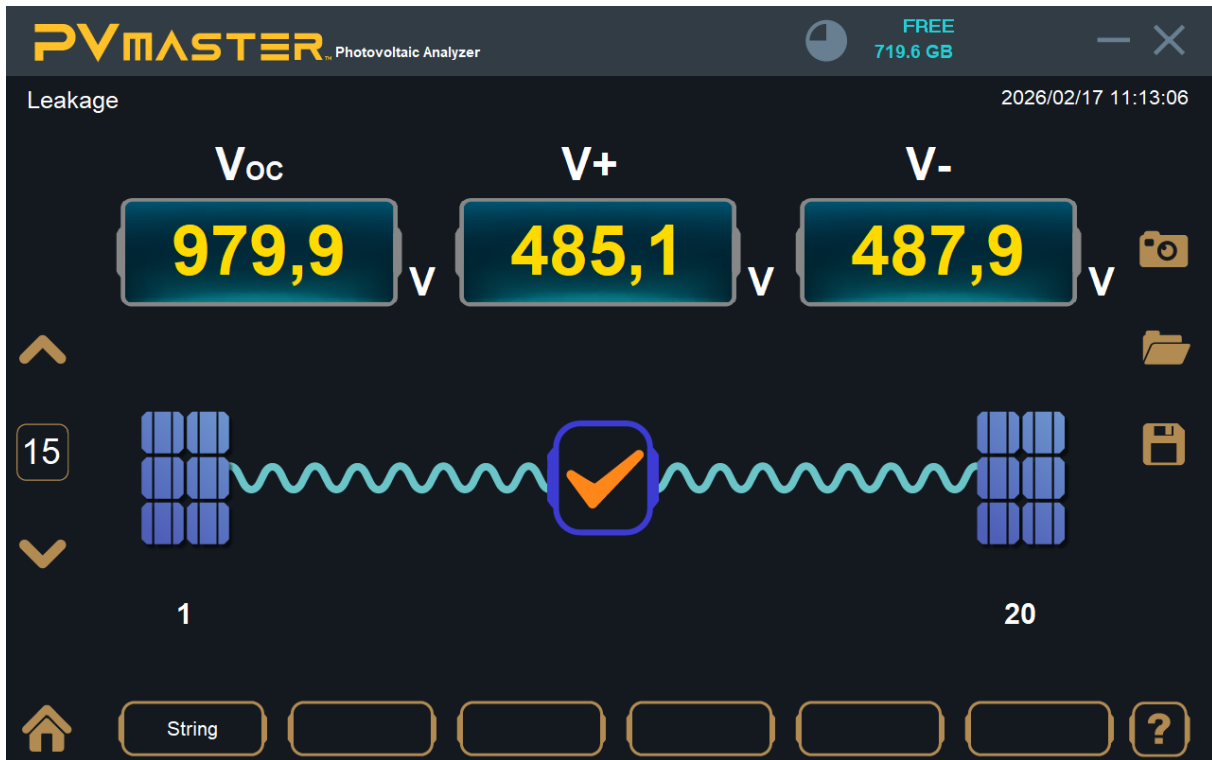

IMPORTANT!

Do not perform an IV curve measurement on strings with leakage errors!
There is a danger to life!



IMPORTANT!

Leakage measurement must not be carried out for PV systems where one pole is at earth potential (e.g. - to GND).



5.6.1 String/Array

The screenshot displays the PVMASTER Photovoltaic Analyzer interface. At the top, it shows 'Leakage' and the date '2026/02/17 11:19:32'. The main display area features three large digital readouts for voltage measurements: V_{oc} at 979,9 V, $V+$ at 485,1 V, and $V-$ at 487,9 V. Below these, a schematic diagram shows two solar panel arrays connected by a wavy line representing a string. A blue checkmark is placed on the wavy line, indicating a successful test. A 'Measure' menu is open, showing options for 'Array', 'String', and 'String'. The number '15' is visible on the left side of the interface, and '20' is visible on the right side. The bottom of the interface has a navigation bar with a home icon, several empty slots, and a help icon.

MESSTECHNIK



5.7 IV Curve

The IV Curve function offers various features and display options, which will be explained in the following points. To start the measurement, click on 'Start'. You will then see the IV Curve and the ability to toggle STC (Esti. 1) on and off. On the right, you can view the Solar Irradiance, Ambient Temperature, and Module Temperature (in degrees Celsius).



IMPORTANT!

**Do not perform an IV curve measurement on strings with leakage errors!
There is a danger to life!**



Note: For PV systems where one pole is at earth potential (e.g. - to GND), the IV curve may only be carried out if proper operation of the PV system has been ensured beforehand. Otherwise, the measurement is carried out at your own risk.

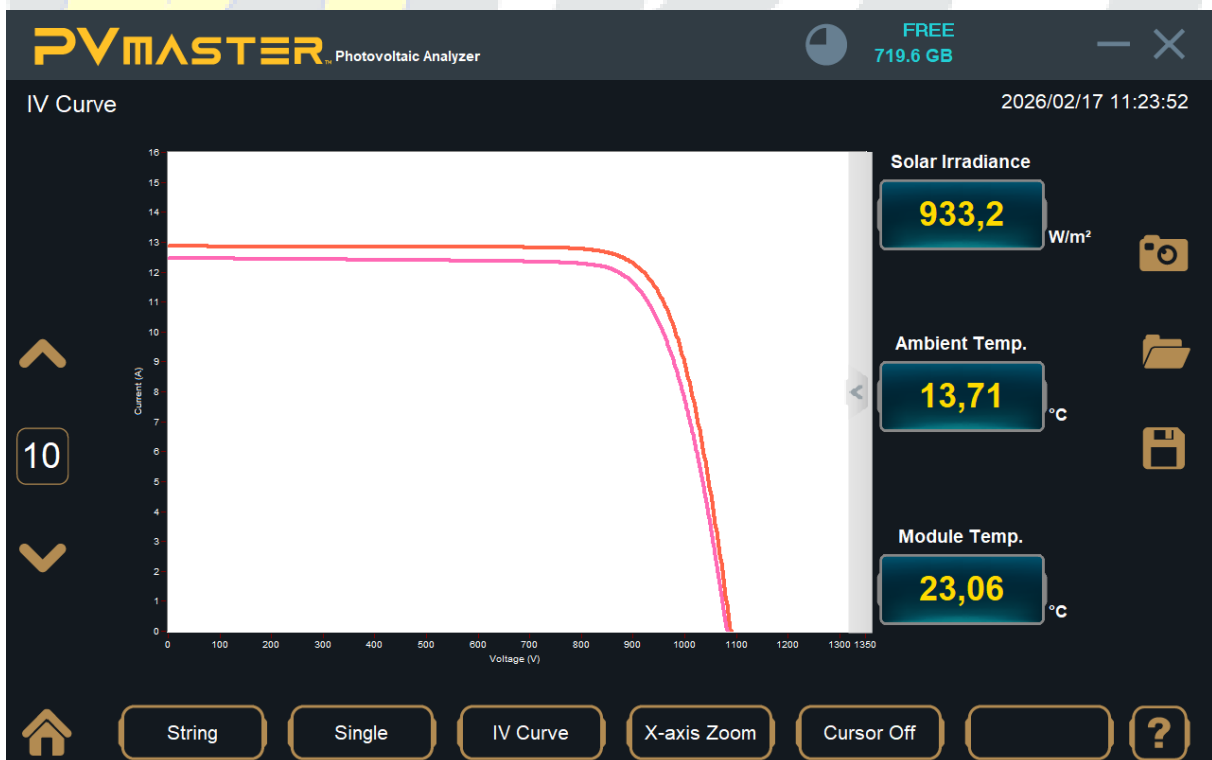



5.7.1 String/Array

You can switch between String and Arrays easily.





5.7.2 Data display

You can switch between different display options, including Single and All.



5.7.3 IV Curve/Array Data

You can toggle between two modes by clicking on 'IV Curve'. You can choose either the IV Curve view or access the Array Data view. If you select the Array Data view, as shown in the next point, you can choose between 'Summary' and 'Detail'.





5.7.4 Array data – Detail/Summary

The most important characteristics (see chapter 3.6.4) of an IV curve measurement are displayed in the Array Data tab.

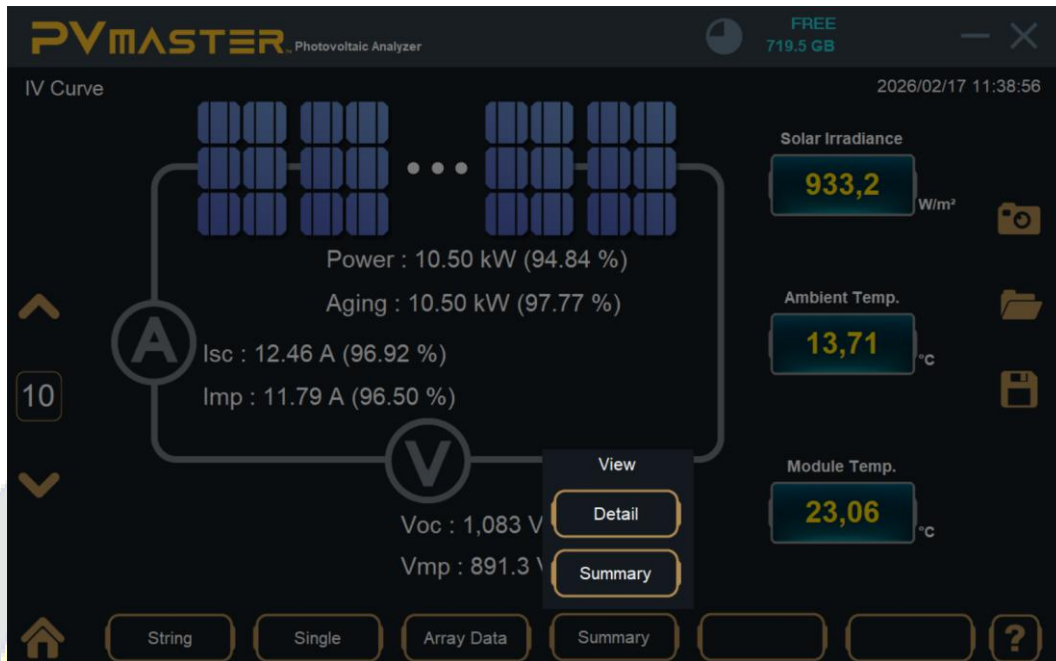

5.7.5 Array Data – Detail

When you activate 'Detail', you will get a tabular overview of the measurement values.

Two different calculation models are used in the PV Master. The basic 1 diode model and the advanced 1 diode model. These can be compared and represent the expected curve.

	Measurement	Basic 1-Diode	Advanced 1-Diode
Power			
W	10,505	9,547	11,077
%	94.84	86.19	-
Power (Aging)			
W	10,505	9,261	10,744
%	97.77	86.19	-
Vmp			
V	891.3	866.8	907.0
%	98.28	95.57	-
Imp			
A	11.79	11.01	12.21
%	96.50	90.18	-
Voc			
V	1,083	1,078	1,091
Isc			
A	12.46	12.13	12.86
Fill Factor			
	0.779	0.730	0.790
Rs			
Ohm	>100,000	22.29	9.92
Rsh			
Ohm	5,001	5,001	5,001



The calculation of R_s and R_{sh} is done as following:

Calculation R_s :

The series resistance is calculated by slope between V_{oc} and 5% of I_{sc} .

Calculation R_{sh} (R_p):

The shunt resistance is calculated by the slope between I_{sc} and 5% of V_{oc} .

5.7.6 Array Data – Summary

When you activate 'Summary', you will get a graphical overview of the measurement data.

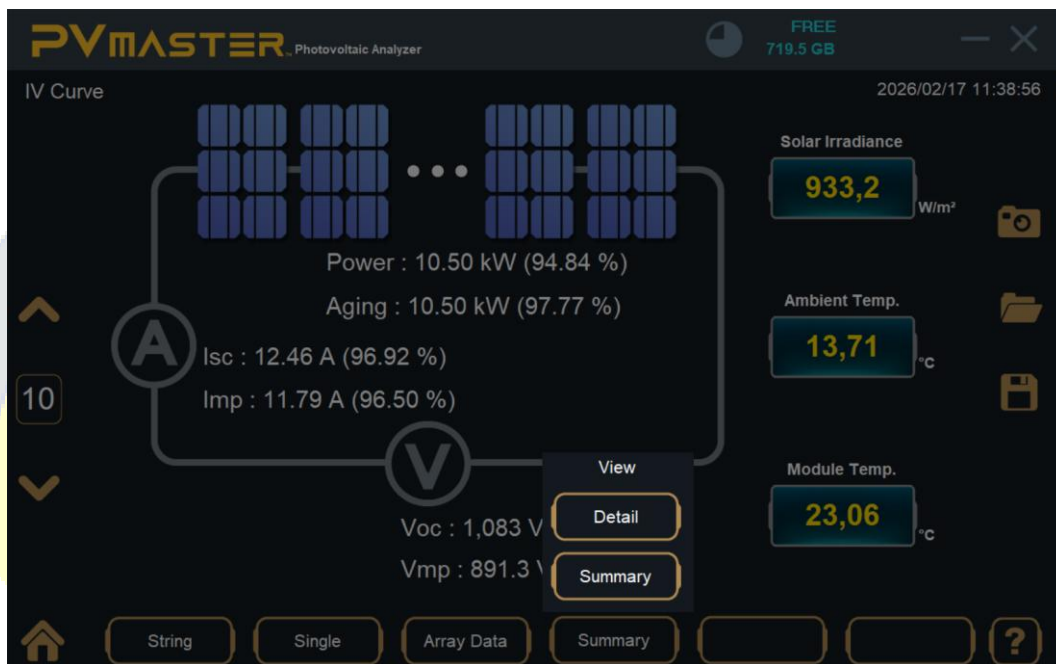

MESSTECHNIK



If you choose “Array Data” while displaying all IV curves, a bar graph diagram will be shown. In this diagram various values (Pmp, Vmp, Imp, Voc, Isc, FF, Rs and Rsh) can be displayed of each string. You can choose between absolute values and ratio.



5.7.7 Graphic Tools

For data analysis, various tools are available to you.

Click Unzoom: Zooms out one step on click on diagram.

Click Zoom: Zooms in one step on click on diagram.

Free Zoom: Create a square by clicking, holding and dragging the mouse to zoom in.

Y-axis Zoom: Enlarge the Y-axis by clicking and dragging the mouse.

X-axis Zoom: Enlarge the X-axis by clicking and dragging the mouse.

Move: Lets you move the IV curve within the diagram by clicking and dragging the mouse.

Reset: Resets everything to the initial view.

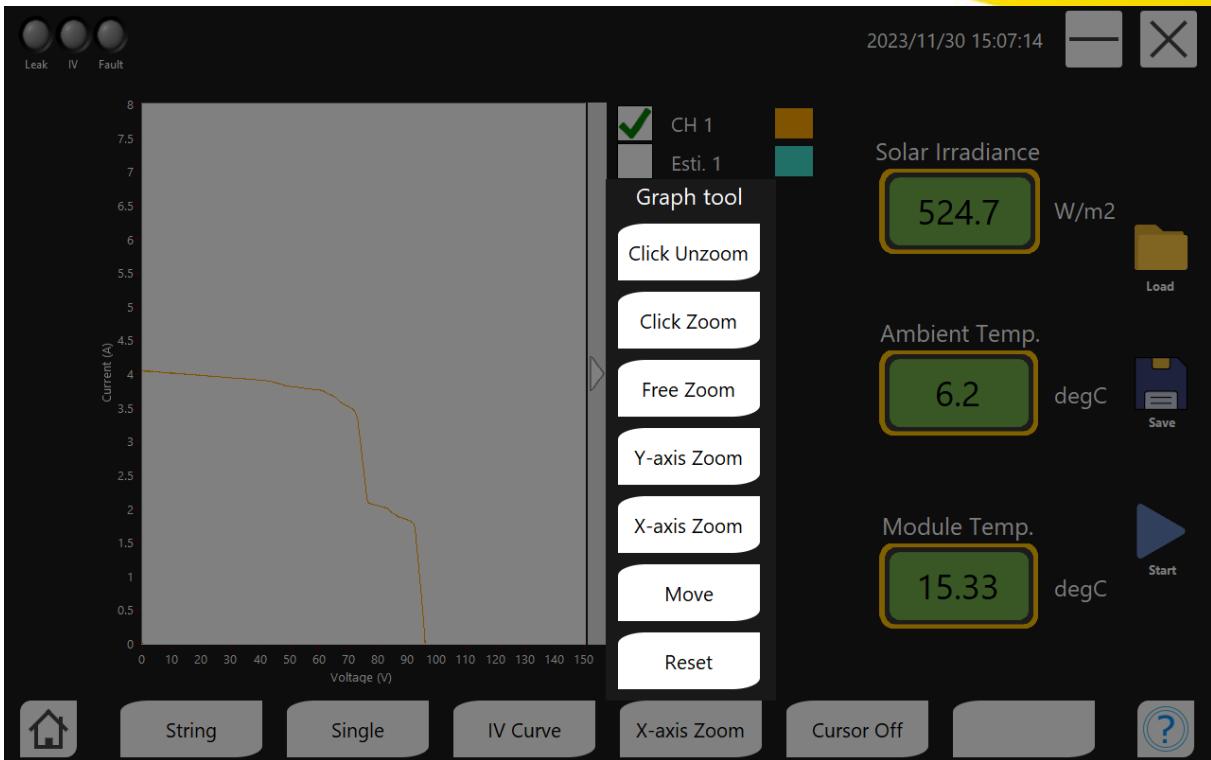

5.7.8 Cursor Toggle

You can activate the cursor, giving you the ability to traverse each point of the IV Curve with the cursor. In a pop-up table, you can view the cursor data (see the following point).

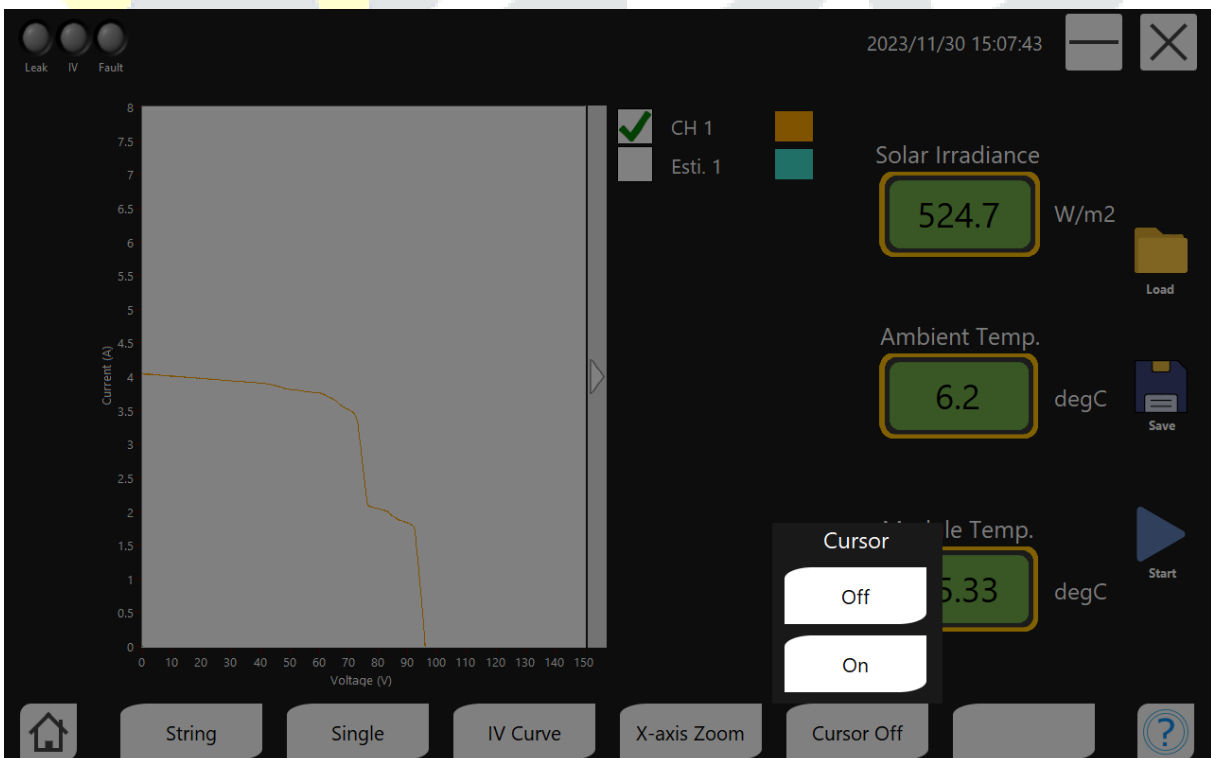



5.7.9 Cursor On

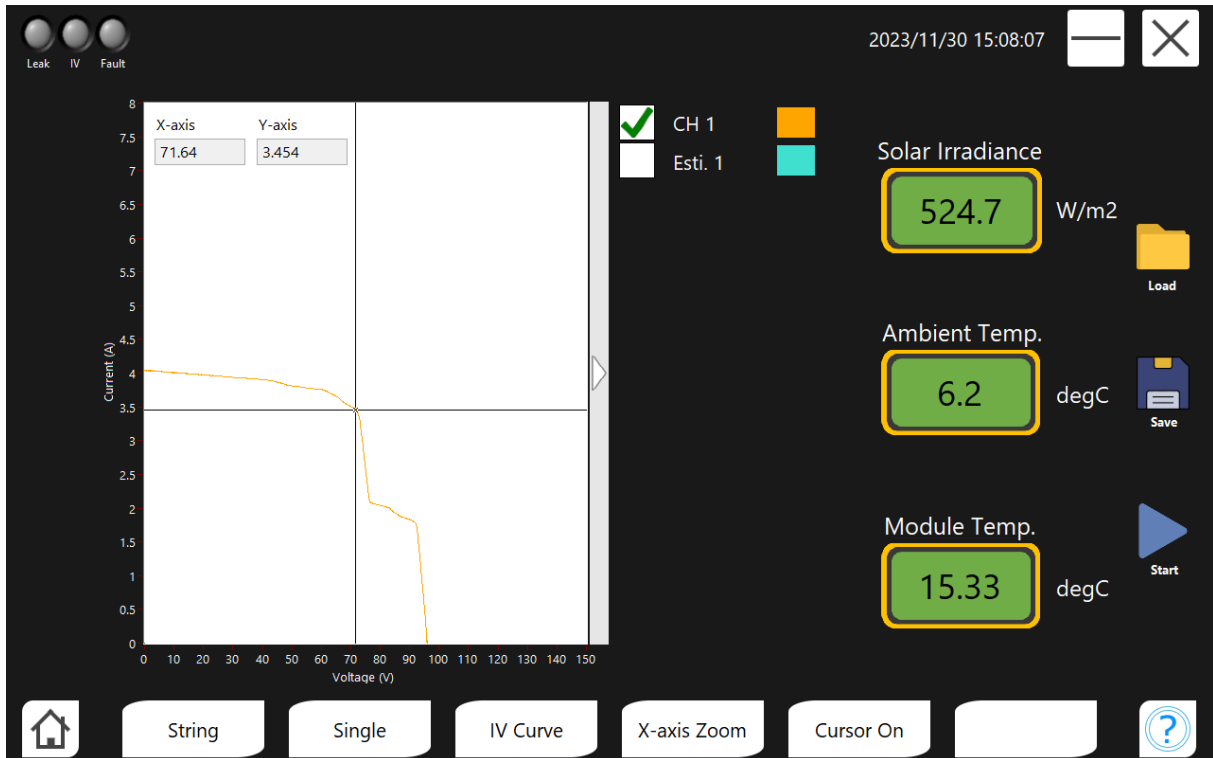

5.8 Multimeter functions

In the multimeter, you can display various digital displays, including voltage, current, temperature, and solar irradiance. You can also customize the time and quantity of displays. To change a display parameter, click on a variable (e.g., voltage) and then select the desired display; it will be reassigned accordingly. By clicking on the grey area above the display (CH1), you can change either the input channel (if more available, like for Temperature) or change between Average (Avg.) or RMS value.

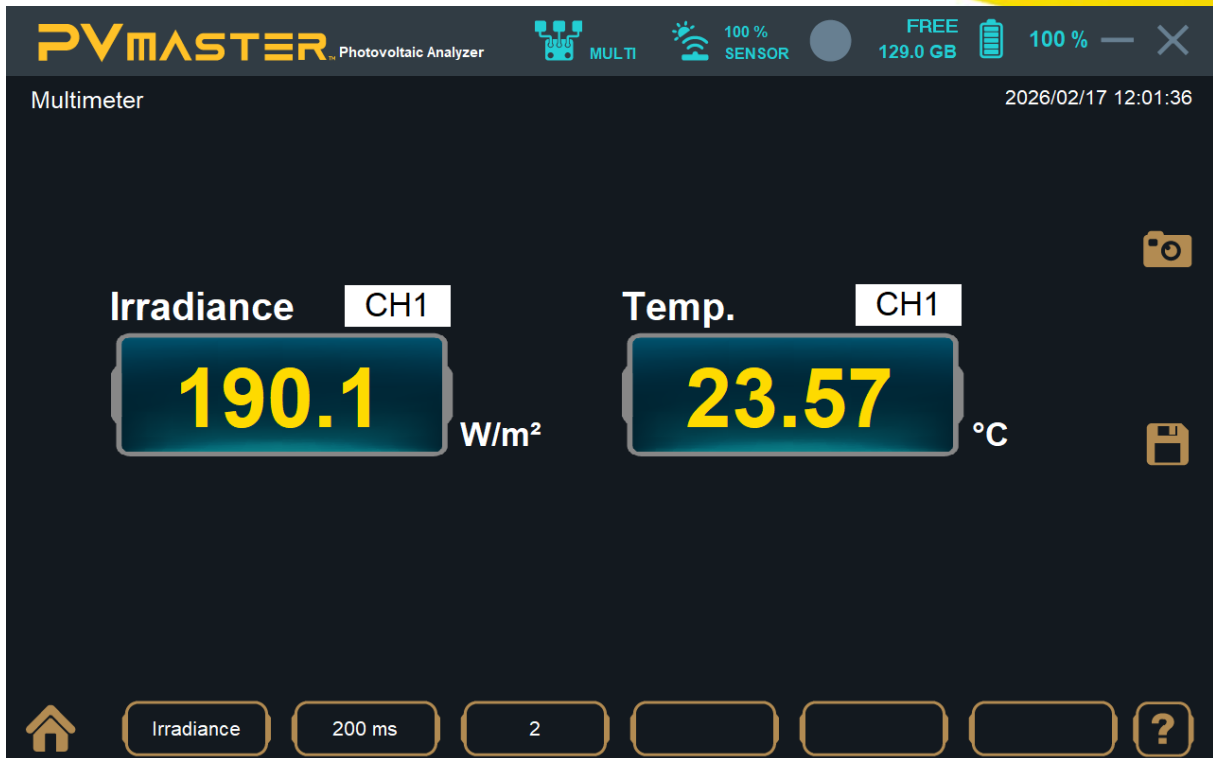

5.8.1 Input source

You can switch between temperature, irradiance, current, and voltage. To assign to a display, first click on the variable (e.g., current), and then click on the display. This will assign the clicked display to the new variable.





5.8.2 Period

You can adjust the update rate of the displays as shown in the image below.

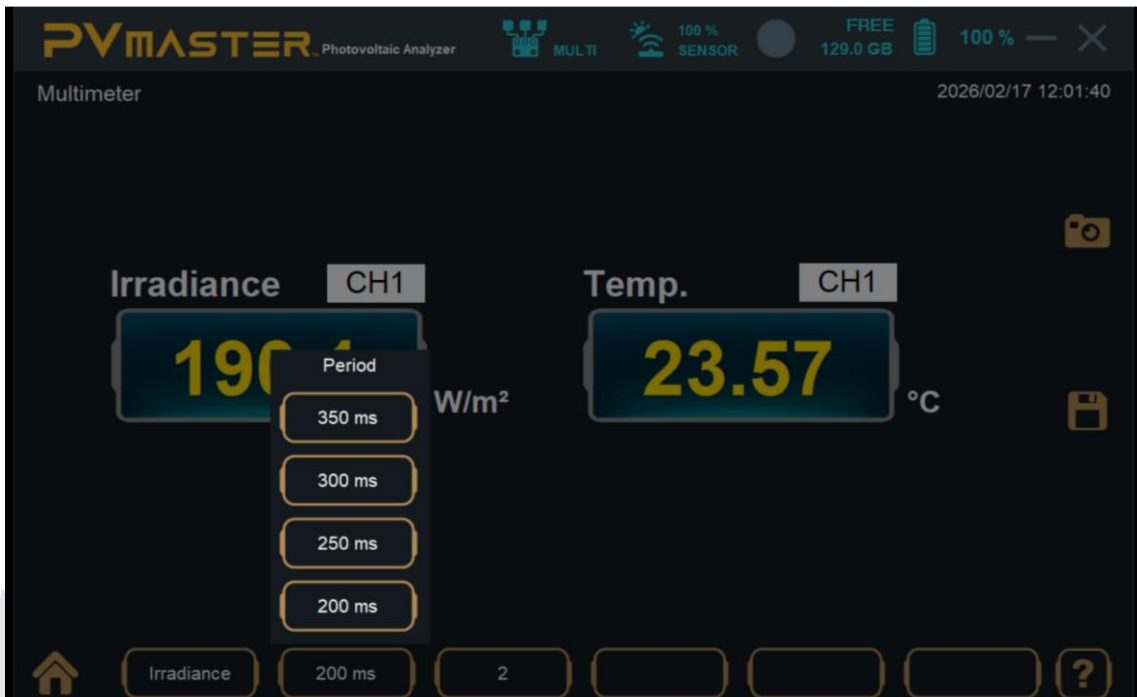

5.8.3 Display (number of measurement points)

You can display a varying number of screens by selecting according to the list.





PVMASTER Photovoltaic Analyzer

MULTI 100 % SENSOR FREE 129.0 GB 100 %

Multimeter 2026/02/17 12:02:44

Irradiance CH1	Temp. CH1
191.8 W/m ²	23.98 °C
Irradiance CH1	Temp. CH2
191.8 W/m ²	21.62 °C

Temp. 200 ms 4 ?



MESSTECHNIK



5.9 Automatic Report

In the first step, basic system data such as the name of the owner, the technician, contact details or the size of the system can be entered to create the report.

The screenshot shows the 'Basic Information' form in the PVMASTER application. The form contains the following fields:

Operator Name	
Operator Contact	
Inspector Name	
Inspector Contact	
Client	
Date of Inspection	
Time of Inspection	
Name of Site	
Location of Site (Address)	
Location of Site (latitude and longitude)	
The number of Series Connection	
The number of Parallel Connection (Channels)	
PV Station Size (W)	
Installation Degree (Angle)	

At the bottom of the screen, there is a navigation bar with icons for Home, IV, Basic Info., and a help icon.

Notes and recommendations from the technician can be added under “Remark”. The technician's and customer's signatures can be added under Signature.

The screenshot shows the 'Basic Information' form with a dropdown menu open over the 'Remark' field. The dropdown menu contains the following options:

- Information
- Remark
- Signature
- Basic Info.

The form fields are the same as in the previous screenshot.



5.10 Automatic Diagnosis

For automatic diagnosis, the string to be analyzed must be selected using the arrow buttons on the left. Then simply press the play button.

The system recognizes different error categories which are described below:

- 1 - Steps: Steps are an indication of shading or contamination of certain modules in the string
- 2 - Low current: This type of error can occur due to bypass diode errors, hotspots, PID and uniform shading
- 3 - Low voltage: This can be caused by PID or incorrect string documentation (e.g. fewer modules in series)
- 4 - Rounder knee: Can occur with ageing, hotspots and module degradation
- 5 - Increased Slope Voltage side: The types of faults here are corrosion, module degradation, wiring faults and increased series resistance
- 6 - Increased Slope Current side: The reason can be PV module degradation or reduced shunt resistance

PVMASTER Photovoltaic Analyzer

Diagnosis 2024/07/03 15:04:35

Current (A)

Voltage (V)

Current

Normal Curve MPP

Voltage V_{oc}

Fault	1	2	3	4	5	6
Fault suspected	1	2	3	4	5	6

–Notice–

1. The result of measurement and inspection refers to the operating condition and possible failure. Since realistic environmental condition of PV system can not be accounted for, when the inspector suspects the presence of irregularities, additional measurement or inspection is encouraged.
2. The appropriate environmental condition for PM10 to make the precise measurement and prediction is when irradiance is over 800 W/m². Therefore, it is strongly advised to carry out inspection under the stated condition.
3. If sudden climatic changes (irradiance, cloud etc.) during the inspection process have occurred, at the discretion of the operator, remeasurement may be required.

–Possible Cause–

Partial shade, Partial soiling, Uniform shade, Uniform soiling

String Single ?



6 Quickstart Guide

This Quickstart guide is intended as a quick measuring guide so that you can use your device as quickly as possible. However, the entire manual should be read and understood before carrying out the measurement in order to avoid personal injury and damage to property.

6.1 Disconnect Inverter and Remove Fuses

System must be completely unpowered. Disconnection of Inverter and then removal of the Fuses.



IMPORTANT!



Before disconnection of the string fuses, the load must be disconnected from the system (switch off the DC switch). It must be ensured that no power is generated by the photovoltaic system anymore and that the DC current is zero. Otherwise, danger to human beings or the measurement instrument is caused. For this purpose, we recommend using a **Direct Current (DC) - Clamp Amperemeter!**



6.2 Connect Strings – Multichannel Measurement with Extensionbox

Connect the strings to the Extension Box as follows:

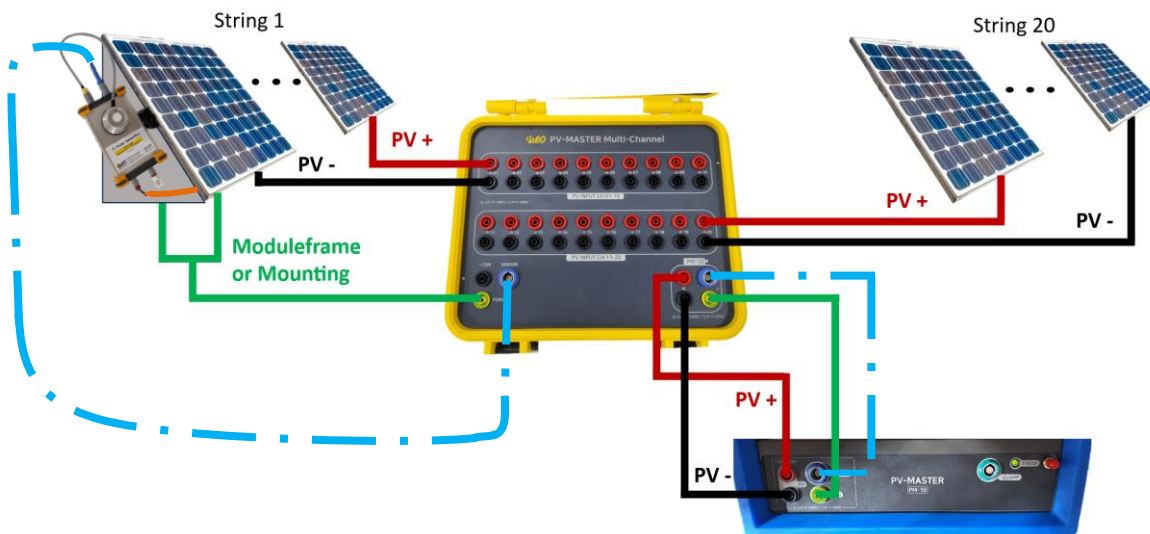

Do not forget to establish the grounding connection to the mounting structure or the equipotential bonding. Use the left socket on the Extension Box for this purpose!



IMPORTANT!

For the Leakage measurement, a good system earthing must be ensured. In the case of open earth, for example, the results could be falsified as the real reference potential does not exist.



IMPORTANT!

Always use the PV+ cable with the integrated fuse as mentioned in chapter 3.6 for safety and protection.



MESSTECHNIK

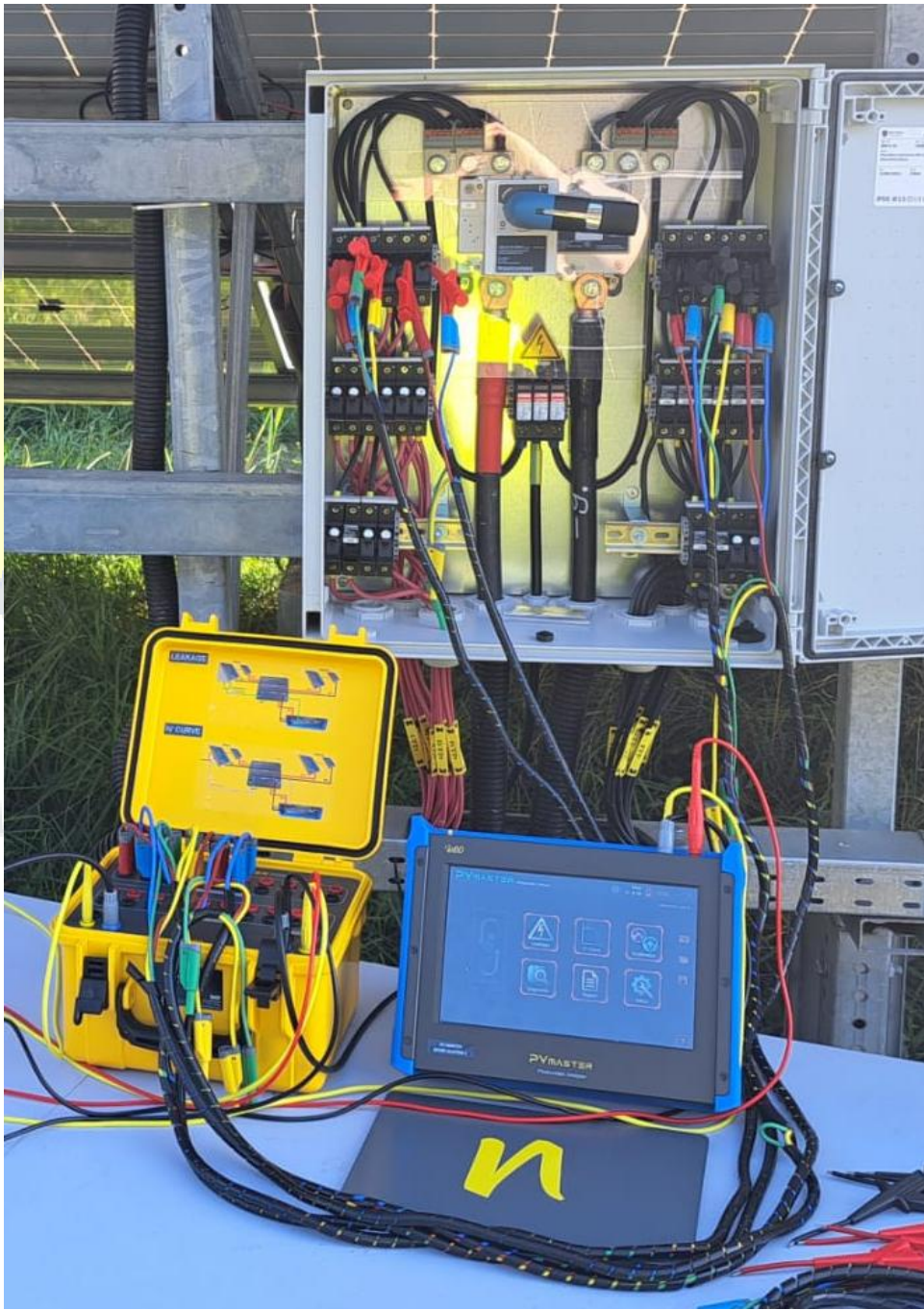



Single Channel Leakage Measurement:

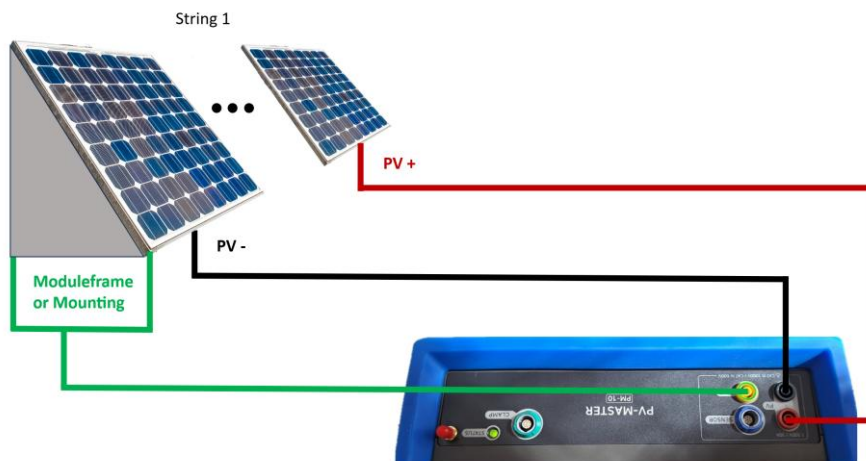

Single Channel IV Curve Measurement:

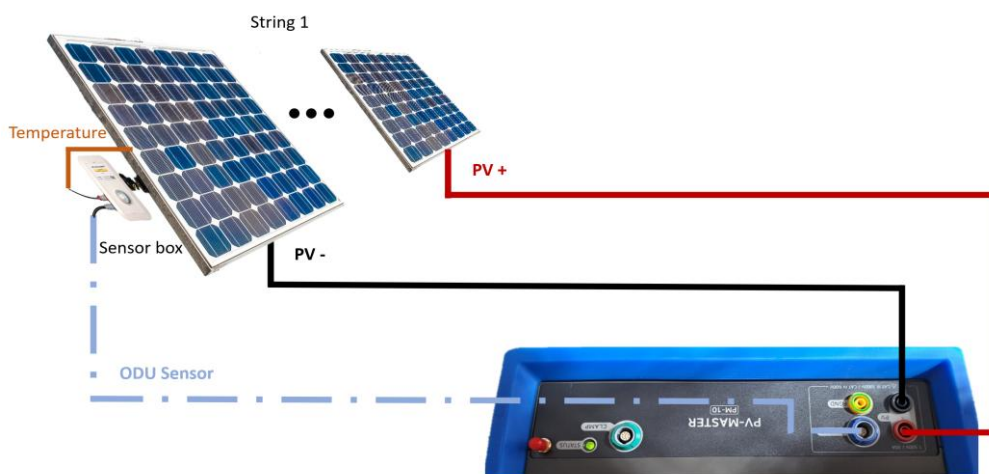

MESSTECHNIK



6.3 Safety Check (Leakage Test) via PV Master

To ensure the safety of the strings/modules in advance, it is essential to perform the Leakage Test **before** conducting the IV curve measurement. It is important to establish a **proper grounding connection to the mounting structure or to the equipotential bonding system**. When using the Extension Box, connect the **system's earth potential to the left side** of the Extension Box. For the connection of the earth potential to the **PV Master** measuring device, use the grounding socket located on the **right side of the Extension Box**.

If a **fault** is detected in a string, it is **not permitted** to perform the **IV curve measurement** on the affected string. **In this case, please remove all faulty strings from the Extension Box!**

The "Distance to Fault" function calculates the possible location of the leakage fault.

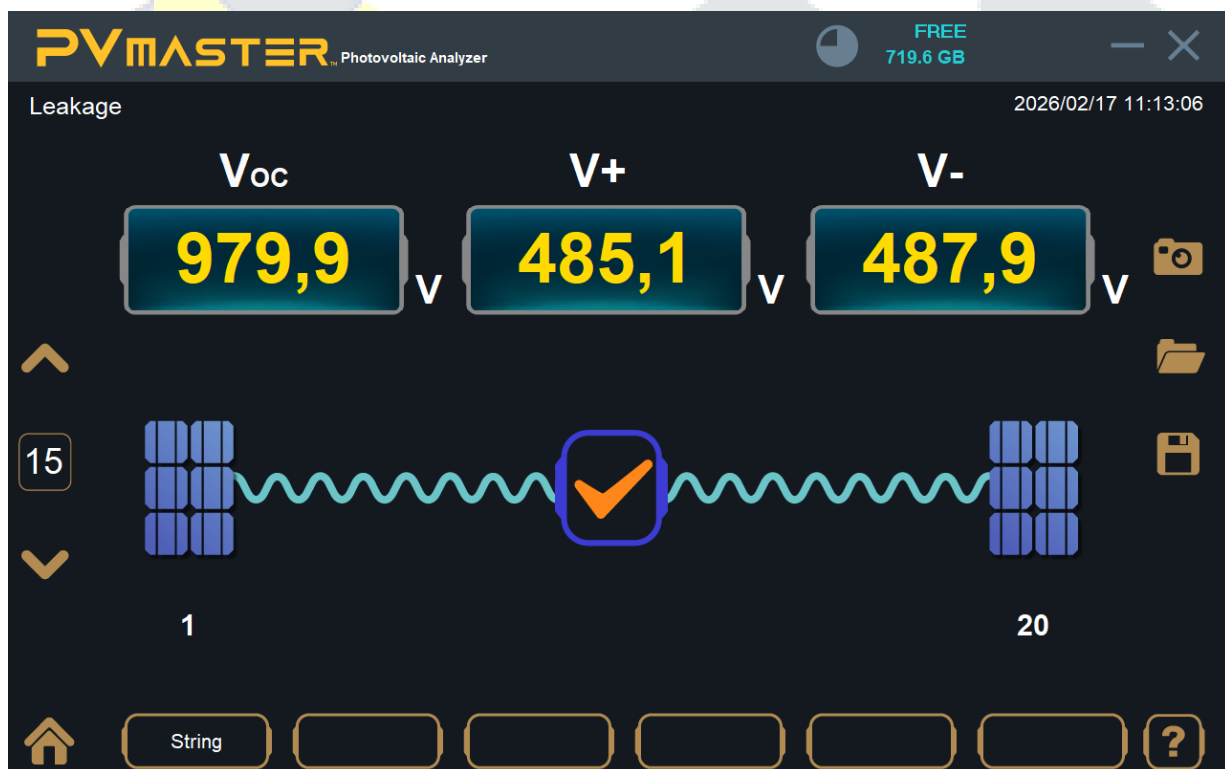

IMPORTANT!
Do not perform an IV curve measurement on strings with leakage errors! There is a danger to life!

IMPORTANT!
Leakage measurement must not be carried out for PV systems where one pole is at earth potential (e.g. - to GND).

If all strings are fault-free (as shown in the figure above) and the deviation between V+ and V- (all) is less than 10%, the IV curve measurement may be continued.



6.4 Install Environmental sensors

Connect the pyranometer, ambient temperature, and module temperature sensors and mount them, for example, as shown in the illustrations below.

The following figure shows the installation of the Sensor Box Basic, mounted using the bracket with integrated ball joint.

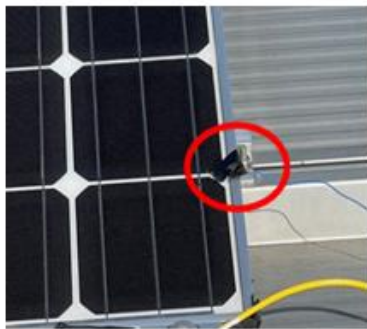
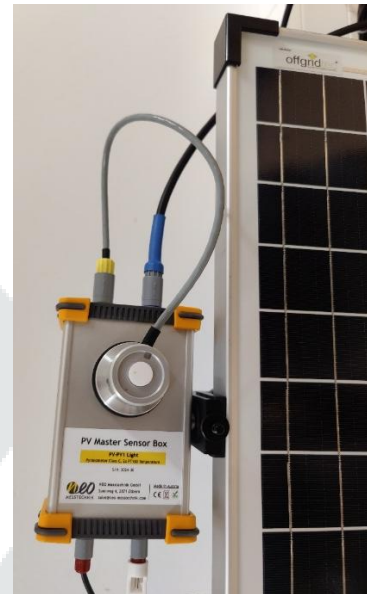

Thermal couple attached on photovoltaic module

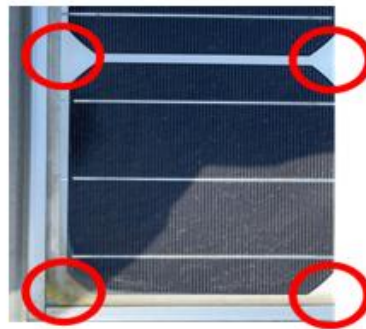

Thermal couple attachable position



Thermal couple on the back of photovoltaic module



The following figure shows the installation of the Sensor Box Expert. For mounting on the PV module, use either the red and black plastic mounting clamps or the silver metal mounting clamps. In the image, the metal clamp is shown on the left and the plastic clamp on the right.



If you are using two pyranometers for bifacial modules, please ensure that the sensor for front-side irradiance is not swapped with the sensor for rear-side irradiance. Please refer to the labeling for correct assignment.



6.5 Instructions for Sensorbox Basic

After connecting the Sensor Box Basic to the PV Master measuring device using the blue ODU communication cable, or alternatively via the left port of the Extension Box, please start the PV Master software.

Navigate to “Setup” → “Sensor” and click on “Refresh”.

If the Sensor Box Basic is not detected, briefly disconnect the cable connection to the Sensor Box. Then reconnect the Sensor Box to the PV Master measuring device and click “Refresh” again.

The connection should now be stable.

To verify the connection, you can check the irradiance under the “Multimeter” menu.





6.6 Instructions for the Sensorbox Expert

6.6.1 Preparation

Power on the Sensor Box:

Switch on the Sensor Box using the ON/OFF switch located below SOL1 and SOL2.

Attention: **The Sensor Box should be fully charged before use.**



Wait at least 1 minute for the device to fully boot up.

Close the PV Master software if it is currently open.

Establish a Wi-Fi connection:

→ On the PV Master measuring device, open the Wi-Fi settings in the bottom right corner.

Connect to the Wi-Fi network of the Sensor Box Expert. **Please ensure that the antenna is properly installed on both the PV Master and the Sensor Box Expert.**

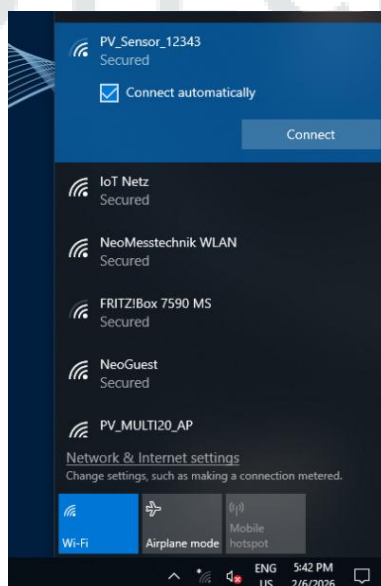



→ Password: 123456789

6.6.2 Launch PV-Master and Connect the Sensorbox

Start the PV Master software.

Navigate to “Setup” → “Sensor” and click on “Refresh”.

If the correct sensitivity is displayed, the connection has been successfully established. Please compare the sensitivity shown in the software with the sensitivity specified on the pyranometer and ensure that the sensor labels are correctly assigned.

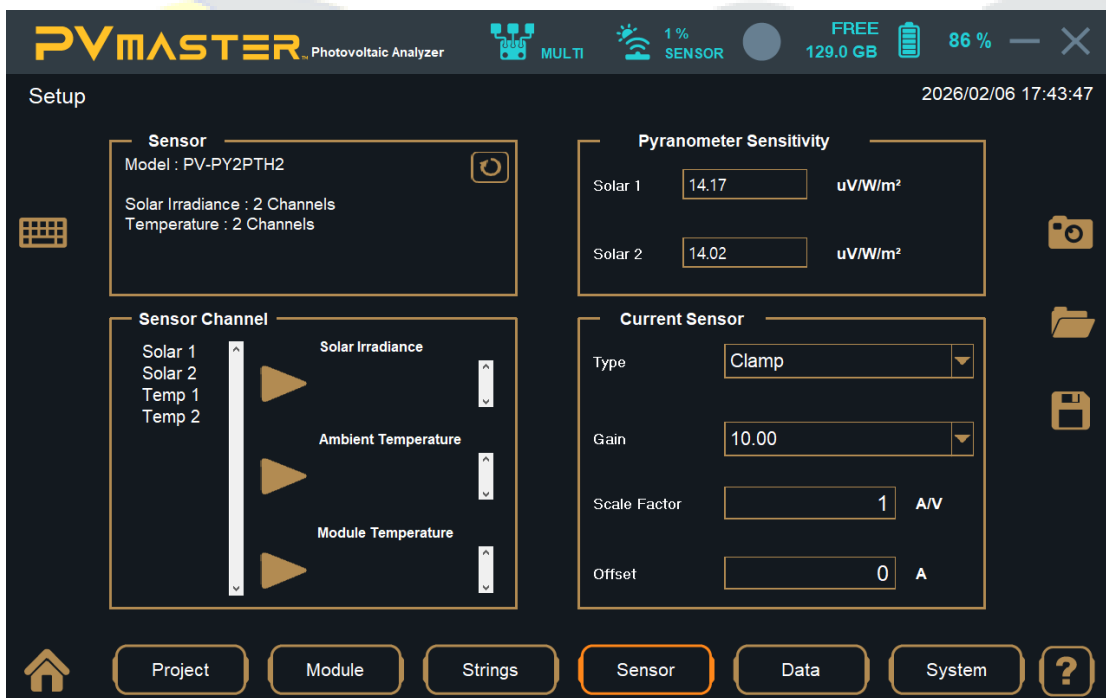

The Sensor Box Expert can be connected either via Wi-Fi or via a wired connection.

For a wired connection, connect the blue ODU communication cable to the blue port on the PV Master and to the blue port on the Sensor Box Expert.

When using the Extension Box, connect the blue ODU communication cable to the sensor port located on the left-hand side of the Extension Box.

6.6.3 Assign Sensors

In the lower left corner, you will see a list of the detected sensors under “Sensor Channel”. The respective sensor is selected by ticking the checkbox (✓). Use the large arrow pointing to the right to assign the selected sensor to the desired measurement channel.



To set the checkbox, click on the desired sensor (Solar 1, Solar 2, Temp 1 or Temp 2).





Proceed step by step as follows:

1. Tick the checkbox (✓) next to the desired sensor (e.g. Temp1).
2. Click the large arrow pointing to the right and assign the sensor to the appropriate channel (e.g. Ambient – ambient temperature).
3. Then untick the checkbox (✓).
4. Now tick the checkbox for the next sensor (e.g. Solar 1) and click the large arrow pointing to the right again to assign it (e.g. as Solar Irradiance).

Important: The checkbox must be unticked after each assignment and then ticked again for the next sensor.

For bifacial measurements with two pyranometers, tick the checkboxes for Solar 1 and Solar 2 simultaneously and then click the large arrow pointing to the right once to assign both irradiance sensors at the same time.

6.6.4 Verify Scaling Factor

Ensure that the scaling factor configured in the software matches the value printed on the pyranometer label ($[\mu\text{V}/\text{W}/\text{m}^2]$). If not, you can adjust the value in the software and then click “Save.”





6.6.5 Save the Setup!



After completing the correct setup, click the save icon.

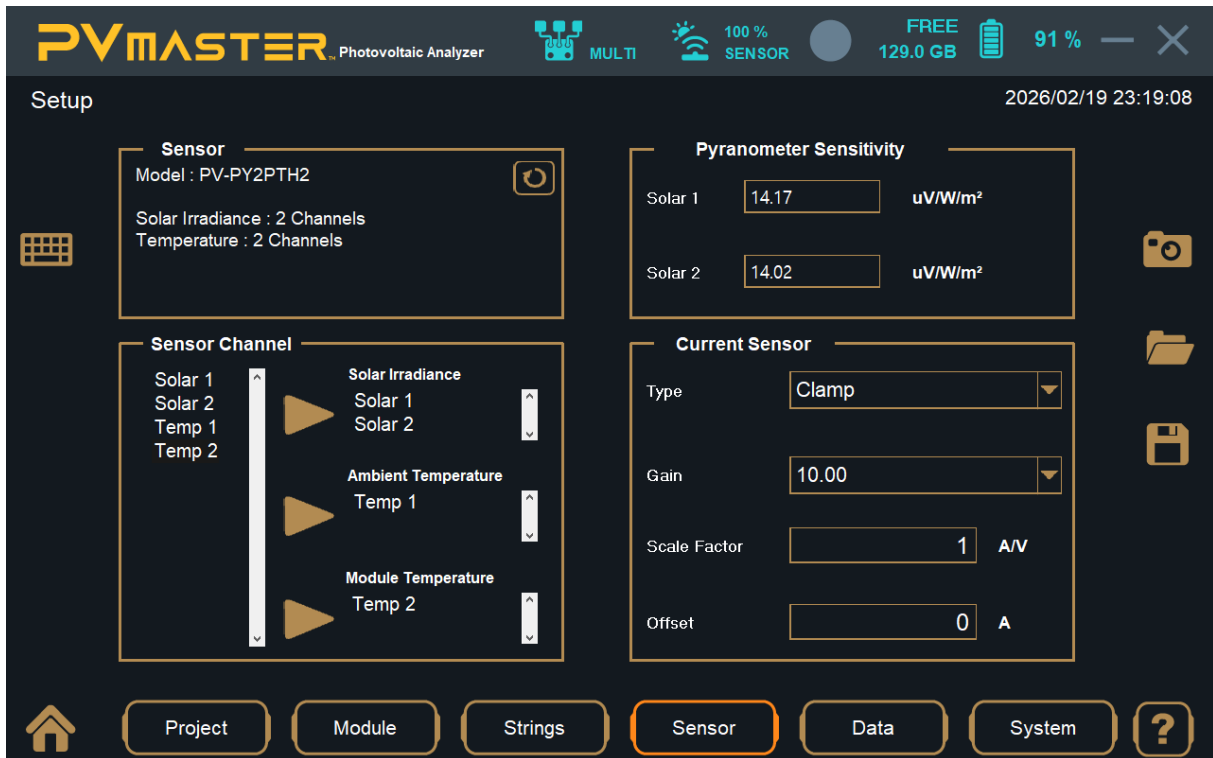



6.7 Software Setup

Perform the String setup and the Module setup. The Module information you can get via the Datasheet and the String configuration from the documentation of the PV Installation.

Module Setup:

Temperature coefficient [%/K]	Crystakline Silicon	Heterojunction	CIGS Modules	CdTe Modules
	Modules	Silicon Modules		
k_{isc}	0,04	0,045	0,01	0,04
k_{uoc}	-0,4	-0,3	-0,3	-0,25
k_{PMPP}	-0,4	-0,3	-0,3	-0,25



String Setup:

Example:

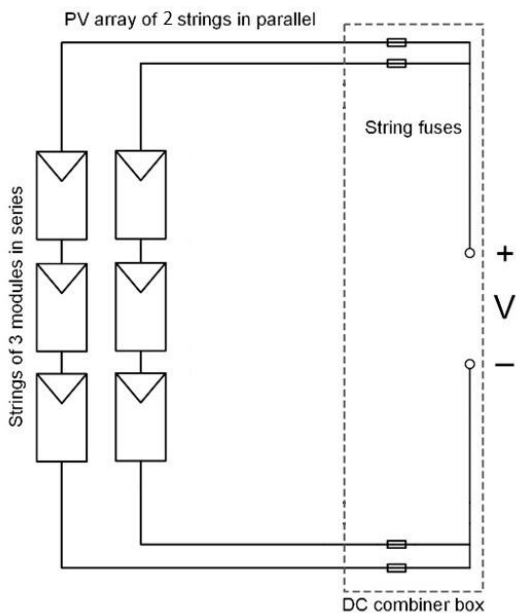

In this example there are 2 strings connected in parallel which meet in the DC combiner box. Each string has 3 modules connected in series. For this example, the number 3 would have to be entered in the software under Modules and the number 2 under Strings.



For most applications where, for example, 22 modules are connected in series in one string and **no parallel string connection is present**, please use the **standard configuration** shown in the **following figure**.

If multiple strings are connected in parallel to a single input of the Extension Box or directly to the PV Master (one positive and one negative terminal), you must enter the number of parallel strings in the field “Array; Parallel Connection of Strings”.

Important: The parallel connection always refers to the number of strings connected to one input (one +/- terminal pair), not to the number of available inputs on the Extension Box. Each input must be considered separately. For example, if two strings are connected in parallel to one single input, the value “2” must be entered, even if the Extension Box has multiple inputs.

In the field “String; Series Connection of Modules”, enter the number of modules connected in series per string (e.g. 22).

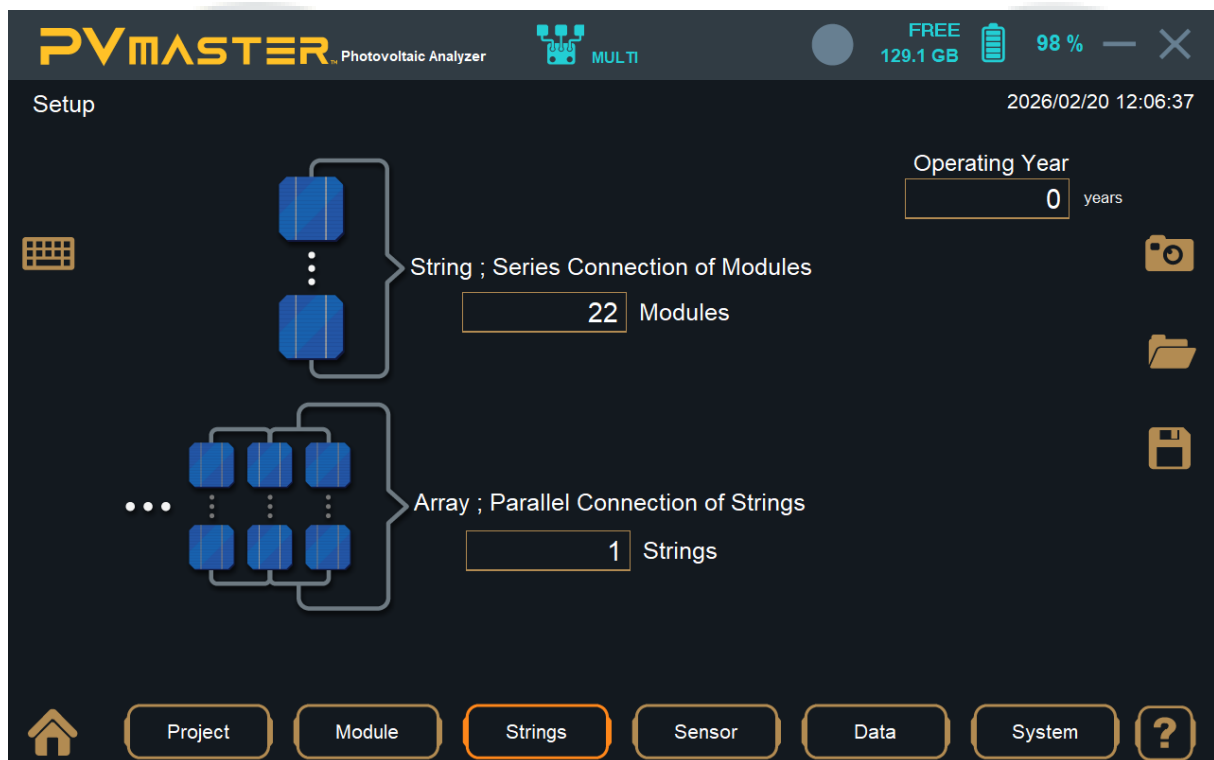

Please strictly observe that the maximum permissible short-circuit current per input of the Extension Box or PV Master is 30 A.

Exceeding this limit can result in severe damage to the measurement electronics, input stages, and internal protection components. An overcurrent condition may lead to permanent destruction of the device and constitutes improper use, which is not covered by the warranty.

Therefore, always verify the expected string short-circuit current in advance, especially when connecting multiple strings in parallel to a single input, to ensure that the 30 A limit is not exceeded.



6.8 Execute Measurement

When all settings and safety measurements are done, you can start the IV Curve Measurement. **It is forbidden to perform IV Curve tracing at strings where safety check (Leakage test) failed. Please disconnect these strings from Extensionbox!**



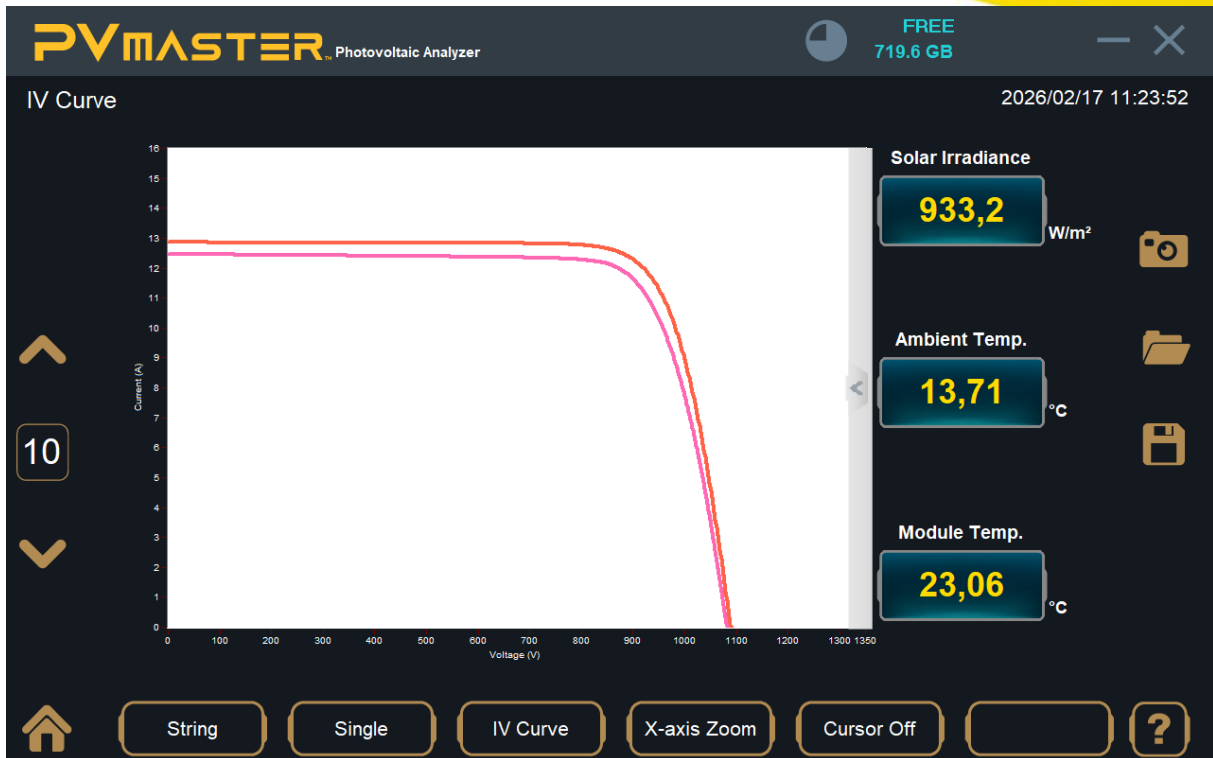

MESSTECHNIK



7 Further Manuals and Links

There are a couple of additional manuals and information available for our products. All information can be found on our webpage in the download section.

www.neo-messtechnik.com

- **Example PV Inspection Report**
An exemplary IV measurement report.
- **Examples of faulty IV curve**
Gives examples of which types of faults affect the IV curve of PV systems and how.
- **NEO Messtechnik Brochure**
Showing all products and accessories available.
- **Quick Start Manual**
This quick start manual is available online and as PDF.





8 Technical Data and Specifications

8.1 Accuracy and Signal Conditioning

ANALOG			HV	LV
Channel	Voltage		1	-
	Current		-	2
Input Range	Voltage		±1600Vp ±800Vp	-
	Current	Clamp	-	Low Voltage Input: ±10Vp MAX Internal Current Sensor: ±30A MAX
DC Accuracy			High Voltage Input: ±0.05%FS	Low Voltage Input: ±0.05%FS Internal Current Sensor: ±0.5%FS External Current Sensor: see datasheet
Gain Linearity			-	20ppm (MAX)
Gain Drift Range			-	20ppm/K (MAX)
Offset Drift			6mV/K (MAX)	26uV/K (MAX)
Input Resistance			10Mohm	10Mohm
ADC	Type		SAR	
	Data rate		1Msps(MAX)	
Filter Bandwidth	-3dB BW	Analog		510kHz 4th Order Butterworth
		Digital (FIR)		241kHz@1Msps 160kHz@600ksps 121kHz@500ksps 70kHz@144ksps 68kHz@140ksps 11.5kHz@24ksps 9.6kHz@20ksps,140ksps
	-0.1dB BW	Analog		160kHz 4th Order Butterworth
		Digital (FIR)		220kHz@1Msps 153kHz@500ksps 110kHz@600ksp 68kHz@144ksps 66kHz@140ksps 11kHz@24ksps 9.2kHz@20ksps,140ksps
Measuring BandWidth	-3dB		510 kHz	Low Voltage: 510 kHz Internal Current Sensor: 300 kHz
	-0.1dB		160 kHz	160 kHz
Typical SNR			90dB	
Typical CMRR			85dB	
Current Sensor Power Supply			-	Bipolar ±15V(1.3A), Unipolar +9V
TEDS	Current		-	1 TEDS for All CH
Isolation Type			CH-CH	CH-GND



Isolation Voltage	6kVp	CAT III 1000V
-------------------	------	---------------

8.2 IV-Curve Specifications

Analogue			
Channel	I-V Curve		1 (Optional; max 20)
	Multimeter		Voltage 1 CH, Current 1 CH
	Environmental Sensor		Solar Irradiance
Temperature			Max. 5 CH
Input Range	I-V Curve	Voltage	± 1500 Vp MAX
		Current	± 30 Ap MAX
Communication for Environmental Sensor			RS485 / Wifi 802.11 b

Data points for IV-Curve Measurement

Sampling Rate	Data Points
100k	229
200k	457
300k	686
400k	914
500k	1143
800k	1828
1M	2285

8.3 Environment and Mechanical

Processor		Intel® Processor E3940 @ 1.6GHz
Storage		2x 256 GB Samsung SSD
Display		10.1" TFT LCD (Touch Screen), 1280x800
PC interface		2xUSB 3.0, 1xUSB 2.0, 1x HDMI
Battery (Li-ion)	Capacity	90 Wh
	Charging Time	About 4 hours 10 min.
	Operating Time	About 4hours 40 min. (Maximum)
Power supply		DC 12 VDC
Size (width x length x height)		298 x 225 x 95 mm
Temperature range	Operating	0°C ~ +60°C
	Storing	-20°C ~ +80°C



A large, stylized version of the 'weo' logo. The 'w' is a circle with diagonal yellow and gray stripes. The 'e' and 'o' are solid gray. Below the 'weo' logo, the word 'MESSTECHNIK' is written in a large, uppercase, sans-serif font, matching the color of the 'e' and 'o' in the logo above.



8.4 DC Clamp 2000DC

CLAMP-2000DC	
Type	Hall Effect
Range	20 A AC rms
Bandwidth	40 Hz to 20 kHz ¹⁾ [-3dB]
Accuracy [+25° C]	DC (0 - 1000A) ± 0,8 % of reading ± 0,5 A DC (1000 - 1500A) ± 1,8 % of reading ± 0,5 A Overall Acc. (0 - 1000 A) ± 2,5 % of reading ± 0,5 A ³⁾ Overall Acc. (1000 - 1500 A) ± 3,5 % of reading Overall Acc. (1500 - 1800 A) ± 5 % of reading
Phase Error [50Hz]	100 mA - 0,5 A not specified 0,5 A - 1 A ± 2 ° 1 A - 20 A ± 2 °
Sensitivity [mV/A]	10
Temperature Coefficient	± 0,15 % of reading per °C
GENERAL	
Dimension [mm]	205 x 60 x 15
Conductor Diameter [mm]	32
Cable length [m]	3
Operating Temperature	0 °C to +50 °C
Operating Humidity	
Supply voltage	+ 9V
Plug and measure (TEDS)	
STANDARDS / SAFETY	
Safety Standards	EN61010-1:2010 EN61010-2-031:2002 EN61010-2-032:2012
Safety category	CAT I 300V
EMC Standards	EN61326-2-2:2013

¹⁾ Additional error of 1% at 20kHz

²⁾ with NEO calibration typ. ≤ 0,3 % of reading

³⁾ with NEO calibration typ. ≤ 1,5 % of reading



If the measured string or module current is lower than shown in the following table, the shape of the IV curve will be not be representative and the Voc data of the IV curve can be incorrect.

Voltage (V)	Current (A)
1500	0.4
1400	0.37
1300	0.35
1200	0.32
1100	0.3
1000	0.27
900	0.24
800	0.22
750	0.8
700	0.75
600	0.65
500	0.55
400	0.43
300	0.32
200	0.22
100	0.11
90	0.096
80	0.087
70	0.075
60	0.064
50	0.054
40	0.043
30	0.032
20	0.022
15	0.016





8.5 PM10 N-type PV Module Testing

The PM-10 is capable of measuring the IV curves of N-type modules starting with a series connection of two modules. However, when connecting up to four modules in series, the shape of the measured IV curve may become distorted. In conclusion, the PM-10 performs effectively for measuring the IV curves of N-type strings when five or six modules are connected in series. Efforts are currently underway to improve the accuracy of measurements for individual N-type PV modules.

	Module Type	
	P-Type Module	N-Type Module
1 Module	✓	✗
3+ Modules	✓	✓
String	✓	✓

8.6 Power bank usage

When using a power bank, it is important to ensure that it supports Power Delivery (PD). PD is a technology designed for fast, intelligent charging with higher wattage. This technology enables safe, rapid charging without damaging the battery, as the charger provides your devices with the precise amount of power they need.

The power bank should be connected as in the following picture, for this you may use the power bank adapter.



8.7 SENSOR BOX BASIC

Ambient Temperature PT100/PT1000 Sensor



MT-Series - Metal Encapsulated Pt Temperature Sensor

Temperature range -40 °C to +500 °C

Performance Characteristics

- Robust stainless steel housing
- Ideal thermal conductivity
- Highly resistant against most chemicals
- According to DIN EN IEC 60751

Application Examples

- Process industry
- Chromatographs
- HVAC
- High temperature sensing

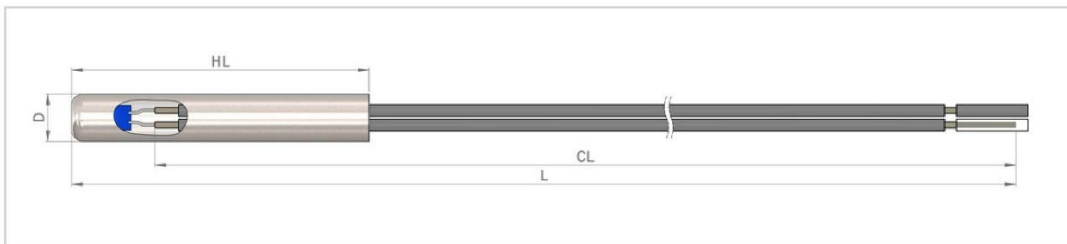

Image for illustration purposes only

Dimensions and Materials

No.	Product Type	Element Resistance R_0 [Ω]	Dimensions & Tolerances (mm)				Conductor			Order Number
			HL	D	CL	L	Core (AWG)	Insulation	Color	
1	MT2060-C	Pt100 / F 0.1	20 ±0.2	6 d10	320 ±10	320 ±10	24/01 Ni	Fiberglass	White	30500109
2	MT2060-C	Pt1000 / F 0.1	20 ±0.2	6 d10	320 ±10	320 ±10	24/01 Ni	Fiberglass	White	31500989



MT-Series - Metal Encapsulated Pt Temperature Sensor

Temperature range -40 °C to +500 °C

Performance Data

No.	Temperature Range	Dielectric Strength AC (Housing)	Response Time Water (v = 0.4 m/s)		Pull Force [N]	Conductor Resistance [Ω/m]	Application
			T0.5 [s]	T0.9 [s]			
1	-40 °C to +500 °C	500 V / 10 s	3.2	9.6	> 88	0.48 ±10 %	Multi-Purpose
2	-40 °C to +500 °C	500 V / 10 s	3.2	9.6	> 88	0.48 ±10 %	Multi-Purpose

Temperature Coefficient

TCR = 3850 ppm/K

Measuring Current

Pt100 Ω: 0.3 to 1.0 mA

Pt1000 Ω: 0.1 to 0.3 mA

(self-heating has to be considered)

Self-Heating (Sensor Element)

0.4 K/mW at 0 °C

Customization Options

- All housing dimensions
- Sensor element (type and resistance)
- Cable material (core and insulation)
- Cable dimensions (length and diameter)
- Connectors
- Certifications (e.g. IMDS, PPAP, IP rating)

Need more information?
Check out our
Sensor Academy!



The information provided in this data sheet describes certain technical characteristics of the product, but shall not be qualified or construed as quality guarantee (Beschaffenheitsgarantie) in the meaning of sections 443 and 444 German Civil Code. The information provided in this data sheet regarding measurement values (including, but not limited to, response time, long-term stability, vibration and shock resistance, insulation resistance and self-heating) are average values that have been obtained under laboratory conditions in tests of large numbers of the product. Product results or measurements achieved by customer or any other person in any production, test, or other environment may vary depending on the specific conditions of use. YAGEO Nexensos does not recommend the use of standard catalogue products or automotive grades for aerospace applications or manned space flight. The customer is solely responsible to determine whether the product is suited for the customer's intended use; in this respect YAGEO Nexensos cannot assume any liability. The sale of any products by YAGEO Nexensos is exclusively subject to the General Terms of Sale and Delivery of YAGEO Nexensos in their current version at the time of purchase, which is available under www.yageo-nexensos.com/tc or may be furnished upon request. This data sheet is subject to changes without prior notice.

YAGEO Nexensos GmbH, Reinhard-Heraeus-Ring 23, 63801 Kleinostheim, Germany

YAGEO Nexensos GmbH, Germany

Web: www.yageo-nexensos.com

Contact: nexensos.america@yageo.com

Document: 20003959423 Part 001 Version 04 | Status: 11/2024

Page 2 of 2



8.8 SENSOR BOX BASIC

Module Temperature PT100 Sensor



TP878.3

Contact temperature probe for solar panels



TECHNICAL CHARACTERISTICS

Sensor	3-wire Pt100
Measuring range	-40...+150 °C
Accuracy	Class B
Use	Contact measurements
Dimensions	10 x 30 x 5 mm
Probe head material	Aluminum
Fixing	Equipped with double sided acrylic tape
Cable	3 x AWG24 TPE isolated Length 3 m Ending with free wires

CONNECTIONS

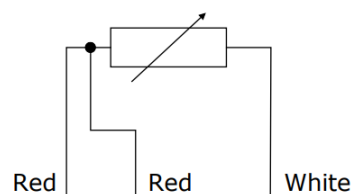



8.9 PYRANOMETER CLASS A, B and C

Depending on your requirements, you can choose between different accuracy classes of pyranometers:

ISO 9060:1990 standards

Pyranometer Specifications	Spectrally Flat Class A	Spectrally Flat Class B	Spectrally Flat Class C
Response time (95% response)	< 15 S	< 30s	< 60S
Zero off-set (a) Response to 200 W/m ² net thermal radiation (ventilated) (b) Response 5 K/hr change in ambient temperature	± 7 W/m ² ± 2 W/m ²	± 15 W/m ² ± 4 W/m ²	± 30 W/m ² ± 8 W/m ²
Non-stability (change per year, percentage of full scale)	± 0.8 %	± 1.5 %	± 3.0 %
Non-linearity (percentage deviation from the responsivity at 500 W/m ² due to any change of irradiance within the range 100 to 1000 W/m ²)	± 0.5 %	± 1 %	± 3 %
Directional response for beam radiation (The range of errors caused by assuming that the normal incidence responsivity is valid for all directions when measuring, from any direction, beam radiation whose normal incidence irradiance is 1000 W/m ²) Commonly defined as up to 80° zenith angle.	± 10 W/m ²	± 20 W/m ²	± 30 W/m ²



8.9.1 CLASS C PYRANOMETER



LPSILICON-PYRA04



LPSILICON-PYRA04 PYRANOMETER

The LPSILICON-PYRA04 pyranometer measures the global solar irradiance (W/m^2) by using a Class C ISO 9060:2018 silicon photodiode.

The special geometry and the diffuser allow to have a pyranometer field of view of 180 degrees according to cosine law.

The pyranometer is suitable for the measurement of natural sunlight. Under conditions of overcast sky or measures of reflected light is recommended to use a thermopile pyranometer (model LPPYRA03 or LPPYRA02).

The LPSILICON-PYRA04 pyranometer can be used in measurements of GLOBAL SOLAR IRRADIANCE in the field of renewable energies such as solar thermal and solar photovoltaic.

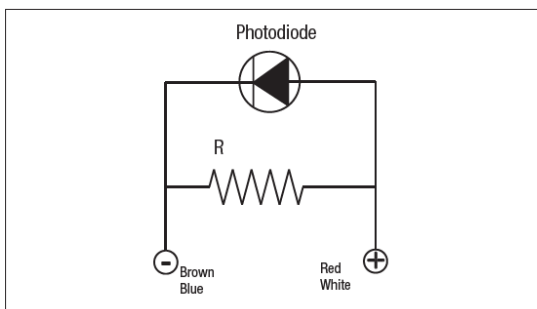

Fig. 2

The base with level LPBL (provided as an accessory) can be used to facilitate the assembly and placement in plan level.

The photocurrent generated by photodiode is converted into a voltage by the shunt resistance. The wiring diagram is reported in Fig. 2 and Fig. 5.

Features

LPSILICON-PYRA04 with 5 m fixed cable and open wires on the cable end, typical output $20 \mu V/(W/m^2)$. Different cable lengths available upon request.

Electrical properties

The photodiode current signal is converted into voltage through the shunt resistance, according to the Fig. 2.

Directional sensor properties

The measurement of radiation across a surface is possible if the probe surface is a Lambert receiver.

The difference between theoretical and measured response is shown in Fig. 3.

The excellent concordance between the measured response and cosine law allows to use the equipment even when the sun has a very low elevation and then perform corrective actions throughout the year.

Spectral properties

The 97% of solar energy that reaches above the atmosphere (WMO) is confined to 290 nm to 3000 nm spectral range. The ideal tool for measuring this radiation should have a flat response at least in this spectral range. The spectral characteristics of LPSILICON-PYRA04 pyranometer are determined primarily by the photodiode and marginally by the diffuser. The spectral response curve is shown in Fig. 4, together with a typical solar spectrum.

The spectral response of LPSILICON-PYRA04 does not cover all the solar spectrum and is not constant. Reliable measurements can be obtained only if the LPSILICON-PYRA04 pyranometer is calibrated with light whose spectrum is equal to the light to be measured. Under clear sky the value of radiation measured by pyranometer has uncertainty less than 3%. In overcast conditions, at sunrise or sunset, the solar spectrum is quite different from that used to calibrate the instrument and therefore the measurement error increases.

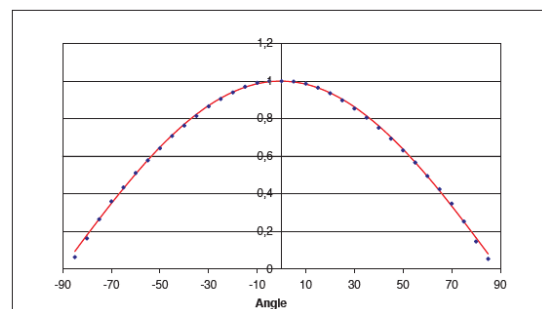

Fig. 3



Positioning

LPSILICON-PYRA04 can be used outdoor for long periods. The probe can be fixed by two M4 threaded holes that are located on the base (Fig. 5) or through the levels based LPBL.

To protect the probe from electrostatic discharges, ground the metallic housing of the pyranometer locally (**note**: the cable shield is not connected to the housing).

You should take care that the diffuser surface is clean and free of deposits. If necessary, the diffuser can be washed with water and a towel for cleaning optical. The probe can be mounted on the support LPBL (accessory) fitted with level for proper placement on work surface.

N.B.: The probe is not designed to be submerged in water.

Calibration

The probe calibration is performed by comparison with a second class pyranometer by using a solar simulator with appropriate filters that reproduce the solar spectrum at AM 1.5 (air mass index 1.5).

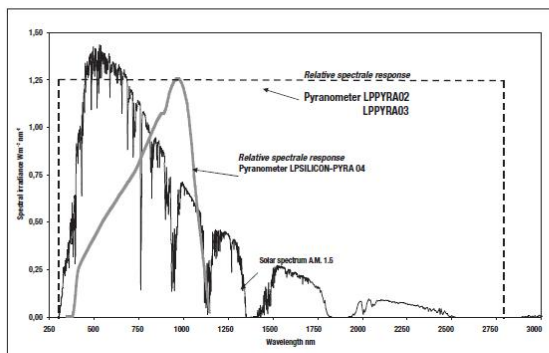

Fig. 4

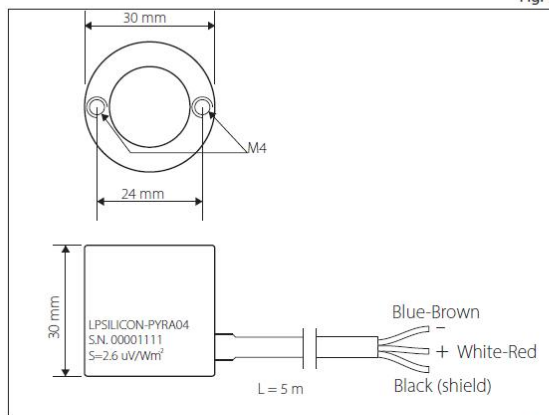

Fig. 5

Connect black (shield) and blue/brown (-) wires together to reduce signal noise.



Technical specifications

Typical sensitivity	20 $\mu\text{V}/\text{W}/\text{m}^2$
Measuring field	0...2000 W/m^2
Spectral range	400...1100 nm
Response time	<0.5 s
Non-linearity	<1%
Non-stability	< $ \pm 2 $ % per year
Temperature drift	< $ \pm 0.15 $ %/ $^{\circ}\text{C}$
Calibration uncertainty	<3%
Directional response @ 1000 W/m^2 according to the cosine law	< $ \pm 30 $ W/m^2
Output	analogue voltage
Working temperature	-40 $^{\circ}\text{C}$...+70 $^{\circ}\text{C}$
Impedance output	25 Ω
Body material	anodized aluminium
Protection Degree	IP67

ORDERING CODES:

LPSILICON-PYRA04: Pyranometer with silicon photodiode with 5 m fixed cable and open wires on the cable end.
Spectral range: 400...1100 nm.

The probe can be connected to the series of converters/amplifiers:
- HD978TR3 and 978TR5 for the 4-20 mA output.
- HD978TR4 and HD978T6 for the 0-10 Vdc output.

LPBL: Base with levelling device for LPSILICON-PYRA04

LPSILICON-PYRA04BL: Pyranometer with silicon photodiode with 5 m fixed cable and open wires on the cable end.
Spectral range: 400...1100 nm. Supplied with base with levelling device.





8.10 Scope of Delivery

With the instrument, the following additional components are provided as seen below.

(Touch pencil)



PV Master 10



Power supply and cable



Bag



Sensorbox (optional)



Contact Probes



Alligator clamps 20



Test lead adapters (MC4)
red 1x and blue 1x



Test leads 2m CATIII 1500V
CATIV 1500V, 1x red with fuse, 1x black



Temperatur Sensor
(PT100/PT1000/TCK)



ODU cable



Sensorbox Mounting bracket



Test lead GND



8.11 Accessories

Please check the NEO Messtechnik brochure or webpage (www.neo-messtechnik.com) to see all available accessories for the instrument.

9 Maintenance and Care

Regular calibration

The Instrument must be calibrated at regular intervals as determined by the accuracy requirements of the application. For most applications a one-year cycle is appropriate. Accuracy specifications are only guaranteed if adjustments are made at regular calibration intervals. Accuracy specifications are not guaranteed unless a one-year calibration cycle is followed. Calibration cycles beyond 2 years are not recommended for any application.

Regardless of which calibration cycle you choose, it is always a good to perform a complete readjustment at each calibration cycle. This keeps the instrument within specification for the next calibration cycle and provides the best stability in the long run. Before your instrument is delivered, it is calibrated. Detailed calibration reports can be requested.

Service & Repair

The team of NEO Messtechnik performs any kinds of service and repairs to your system to assure a safe and proper operation in the future. Contact us for more information.

Repair and maintenance work has to be carried out by NEO Messtechnik or an authorised service partners using original spare parts only. by NEO Messtechnik recommends having the system tested and maintained at a Megger service centre once a year. It is not necessary to open the housing of the device to commission and operate the system. Opening the housing causes the immediate termination of all warranty claims!

The connections and connection leads of the system must be regularly tested to ensure that they are free of defects and intact, in accordance with the applicable national and company-specific arrangements.

Storage

If the device is not used for a lengthy period, it should be stored in a dust-free and dry environment.

Display

Do not clean the display with aggressive products such as solvents or spirits. Instead, use lukewarm water and a soft, lint-free cloth for wet wiping, or a microfibre



cloth for dry wiping

Training

We offer various training options (In-House, On-Site, Remote). Contact your local distributor or NEO Messtechnik directly.





Revision History

12.12.2023	Version 1	Initial Version of Manual
18.12.2023	Version 2	1. Revision of Manual
10.01.2024	Version 2.1	New Design
12.02.2024	Version 2.2	Update Report
20.02.2024	Version 2.3	Update Leakage
06.06.2024	Version 2.4	Updated Safety Notes
25.06.2024	Version 2.5	Shipping Instructions
04.10.2024	Version 2.6	PM10 N-type, Power bank usage
08.11.2024	Version 2.7	Why use fused test leads?
30.04.2025	Version 2.8	Sensorbox Expert
27.08.2025	Version 2.9	Added Cyber Security
20.02.2026	Version 2.10	Corrected Sensor Box Expert instructions, software screenshots

Contact

When you are working with our products we want to provide you with the greatest possible benefits. If you need any support, we are her to assist you.

support@neo-messtechnik.com

www.neo-messtechnik.com

Austria:

Sonnweg 4,
A-2871 Zöbern
+43 2642 20 301



Switzerland:

Moosacherstrasse 15,
CH-8804 Au
+41 44 727 75 50